

ENVIRO-TEC[®]
ENGINEERING FOR EXCELLENCE

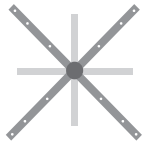

SERIES 700 ANALOG ELECTRONIC CONTROLS

with ACT24 Actuator Supplement

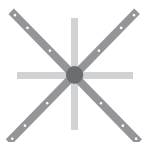
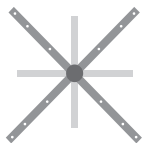

INSTALLATION & OPERATION MANUAL

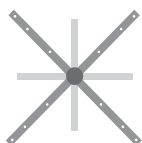
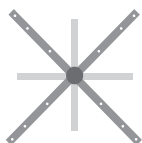

Stock ID: IOM-700

October, 2000

©2000 Environmental Technologies, Inc.

Largo, FL

Series 700 IOM Table of Contents

1.0 DEFINITIONS AND DESCRIPTIONS	
1.1 Thermostat (Figures 1a and 1b).....	3
1.2 Controller (Figures 2a and 2b).....	5
1.3 Actuators (Figures 3a, 3b and 4).....	6
2.0 INSTALLATION	
2.1 Inspection (Figure 5).....	7
2.2 Coordination Of Trades	7
2.3 Thermostat Mounting (Figures 6 through 10).....	7
2.4 Wiring Installation	10
2.5 Controller Wiring (Figure 11)	10
2.6 Thermostat Wiring.....	11
3.0 START-UP AND BALANCE PROCEDURE	
3.1 Initial Start-up Procedure - Test Clip (Figure 12).....	12
3.2 Initial Checks	12
3.3 Air Balancing Procedures	13
Table 3.1 – Control Sequence Charts	14
4.0 TROUBLESHOOTING	
4.0 Quick Reference Table.....	17
4.1 Damper Motion	18
4.2 Fan	19
4.3 Electric or Hot Water Heat	20
4.4 Night Setback	21
4.5 Night Mode	22
4.6 Morning Warm-Up	23
4.7 Auxiliary Minimum	23
4.8 Changeover / Warm-Up	24
4.9 Airflow Readings	25
4.10 No Response to Thermostat.....	25
4.11 Corrective Actions.....	26
5.0 TEMPERATURE CALIBRATION, THERMOSTAT AND DUCT TEMPERATURE SENSOR	
5.1 Thermostat	27
5.2 Duct (Supply Air) Temperature Sensor	28
6.0 SPARE PARTS LIST	
Actuator Replacement	29
Thermostat	29
Controller	29
2.5" x 3.5" and 2" Thermostat Accessories.....	30
7.0 AIRFLOW CALIBRATION CURVES	
SDR, VFR, CFR Volts vs. CFM (Figure 13)	31
SDR, VFR, CFR Δ P (inches W.G.) (Figure 14)	32
SSD, VVF, CVF Volts vs. CFM and Δ P (inches W.G.) (Figure 15)	32
APPENDIX A, ACT24 IOM	33

1.0 DEFINITIONS AND DESCRIPTIONS

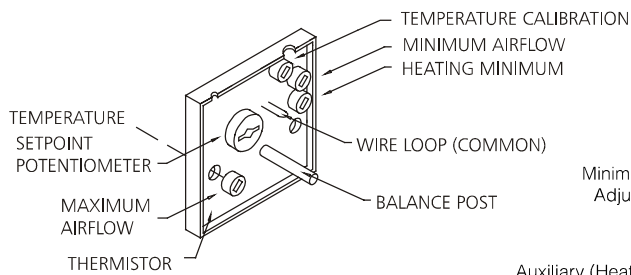

Figure 1a, 2" Square Thermostat

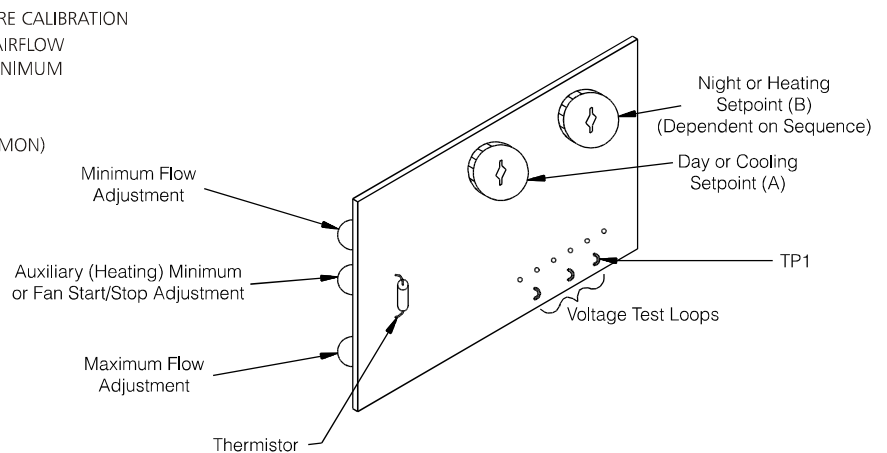

Figure 1b, 2.5" x 3.5" Thermostat

1.1 Thermostats (Figures 1a and 1b)

Two styles of thermostats have been produced. The previous thermostat (beige unit), approximately 2.5" x 3.5" on a 3.5" x 4.5" base, was standard through 1997. It is still supported, and is referred to as the **2.5" x 3.5" Thermostat** throughout the remainder of this manual. The current thermostat (off-white 2" square, low profile unit) was introduced in 1998, and is referred to as the **2" Thermostat** throughout the remainder of this manual. Items common to both are:

- a. **Thermistor** – Glass-encapsulated, hermetically sealed temperature sensing device mounted on front of the thermostat printed circuit board.
- b. **Thermostat Packaging** – Bubble pack design for protection during shipment. Terminal numbers, signal designations, serial number, inventory number and ETI job number are shown on outside of package, as well as Min., Max., and fan CFM on set CFM projects.

1.1.1 2" Thermostat (Figure 1a)

- a. **Setpoint Control** – Hidden version shown. Also available with exposed dial in Fahrenheit or Celsius scale (see Figure 6).
- b. **Enclosure** – Protects thermostat and provides stable temperature environment for sensing. To remove cover, push firmly on one side (not top or bottom) of cover, and pull other side away from base.
- c. **Connectors** – Protected terminal block on back of thermostat base. Terminal designations are engraved on back of base.
- d. **Minimum Flow Adjustment** – White potentiometer on printed circuit board (see Figure 1a). CW rotation increases minimum CFM.
- e. **Maximum Flow Adjustment** – White potentiometer on printed circuit board (see Figure 1a). CW rotation increases maximum CFM.
- f. **Auxiliary (Heating) Minimum Adjustment** – White potentiometer (see Figure 1a) allowing increased flow when heat is energized. CW rotation increases heating CFM. Should always be turned fully clockwise if heating minimum feature is not used.
- g. **Temperature Calibration** – Factory set. Adjustment rarely required.

1.0 DEFINITIONS AND DESCRIPTIONS

1.1.2 2.5 x 3.5" Thermostat (Figure 1b)

- a. **Setpoint Controls "A" and "B"** – Green thumbwheel potentiometers mounted on front of the thermostat printed circuit board. "A" adjusts temperature setpoint for day or cooling operation. "B" adjusts temperature setpoint for night (setback) or heating (changeover) operation.
- b. **Enclosure** – Protects thermostat and provides stable temperature environment for sensing. Vertical fins on cover face must be on left hand side of enclosure directly over thermistor.
- c. **Connectors** – Captive screw type. Terminal designations are printed on solder side of printed circuit board.
- d. **Minimum Flow Adjustment** – Top blue potentiometer on back of printed circuit board (viewed from left side of stat). CW rotation increases minimum CFM.
- e. **Maximum Flow Adjustment** – Bottom blue potentiometer. CW rotation increases maximum CFM.
- f. **Fan Start/Stop Adjustment (optional)** – Middle blue potentiometer on variable volume fan sequences. CW rotation increases CFM at which fan will start (decreasing CFM) or stop (increasing CFM). Full CCW rotation causes fan to start/stop by temperature demand rather than CFM (1° below temperature setpoint).
- g. **Auxiliary (Heating) Minimum Adjustment (optional)** – Middle blue potentiometer allowing increased flow when heat is energized. CW rotation increases heating CFM.

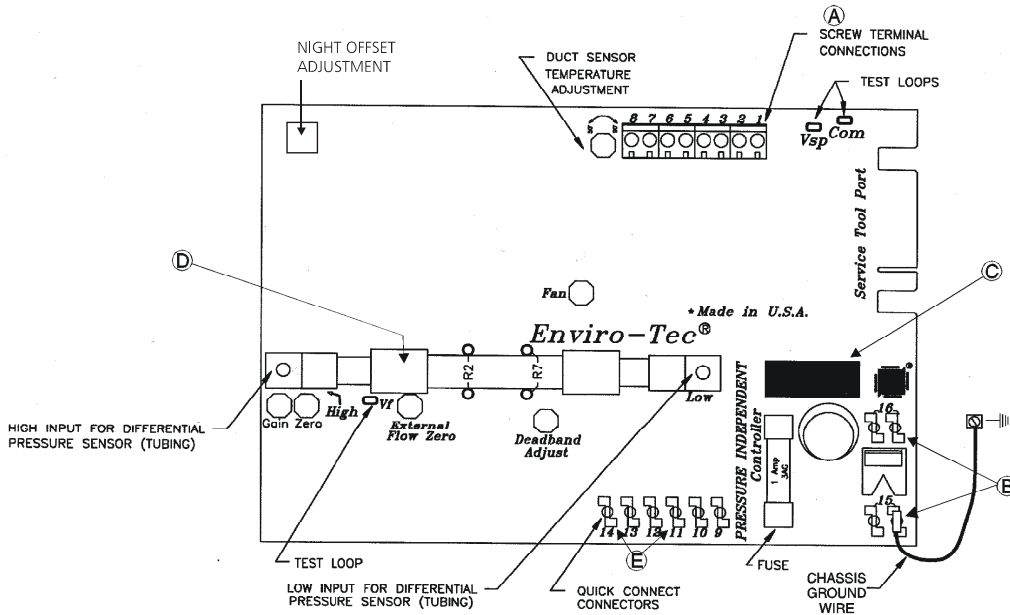

Figure 2a
Controller

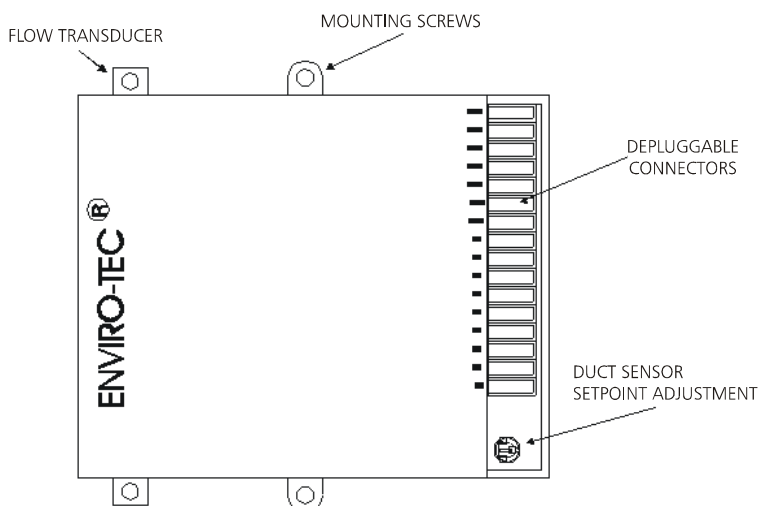

Figure 2b
First Generation Controller
(No Longer Available)

1.2 Controller (Figures 2a and 2b)

Three versions of controllers have been offered. The first generation (Figure 2b) was housed in a black plastic enclosure, used an AC actuator drive, and was standard from 1986 through most of 1990. The latest generation (Figure 2a) uses a blue circuit board, DC actuator drive, and was standard from 1990 through mid-2000. An interim version was offered for around six months in 1990. It was similar in appearance to the latest generation, but used a green circuit board and AC actuator drive.

- a. **Thermostat and Sensor Connectors** – One-piece, captive screw terminal type for reliable connections.
- b. **24 VAC and Control Output Connectors** – Male, 1/4", quick connect type.
- c. **Labels** – Computer printed with serial number, inventory number and ETI job number.
- d. **Flow Transducer** – Device mounted on controller, which produces electronic signal proportional to flow. Tubing for the transducer is connected to the inlet of the VAV terminal at the factory.
- e. **D.C. Actuator Drive** – Incorporates reversing and current limit circuitry, which removes power from motor when a mechanical stop is met.

1.0 DEFINITIONS AND DESCRIPTIONS

1.3 Actuators (Figures 3a, 3b and 4)

Several versions of actuator have been offered. The first generation (Figure 3b) was initially offered with an AC motor through most of 1990. At the end of 1990, a DC motor was substituted for the AC motor. A version with a rectifier board was available for controls with AC drives. In 1992, a rotary actuator was released (Figure 3a). It was used through early 2000, when it was replaced with the ACT24 (Figure 4, Appendix A).

- Rotary** – 90° rotation. Attaches to damper shaft with approximate 1/8" gap between bottom of actuator and bottom of control enclosure and use 2 set screws. Full open to close travel time is 2 to 3 minutes.
- Rack & Pinion** – Rack and pinion type with lubricated steel gear insert in rack for strength. Pin at end of rack attaches to damper shaft with bolt. Rack contains internal stops. Full travel time is approximately 70 seconds. Actuators using this drive train are no longer available. See Section 5 for current substitute.
- D.C. Motor** – Reversible D.C. Motor. Output at pinion gear is approximately 2 RPM, depending on load. Connections are made using 3/16" quick connect receptacles.
- A.C. Motor** – Hansen "Synchron" model is two motors stacked together, each with 24 VAC, 4 W winding. The output at pinion gear is 1 RPM. White wires are used for common, blue wire for CW motor and yellow for CCW rotation. A 13 ohm resistor is provided on the controller to prevent damage by high voltage. Actuators using this motor are no longer available. See Section 5 for current substitute.



Figure 3a, Rotary Actuator

Figure 3b, Rack & Pinion Actuator

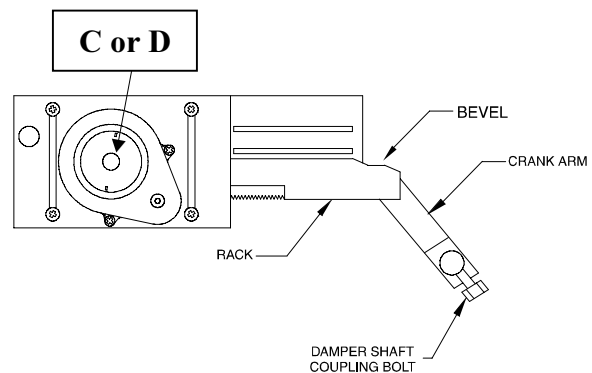

Figure 4, ACT24 Actuator
(See Appendix A)

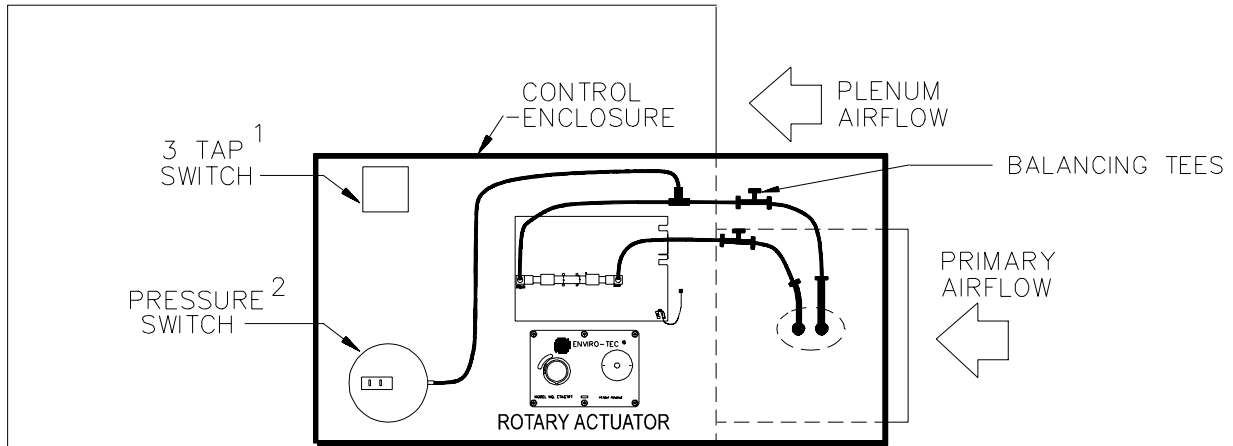

Figure 5, Typical Component Mounting

On units with electric heat, high voltage components are located inside the electric heat cabinet.

2.0 INSTALLATION

2.1 Inspection (Figure 5)

Upon receipt of VAV terminals, check controls for shipping damage such as loose or broken connectors, broken actuator or controller housing, loose or disconnected tubing and loose wiring. Also inspect both before and after installation for damage caused by abuse or mishandling. A diagram of a typical control component mounting configuration is provided above in Figure 5.

2.2 Coordination of Trades

Contractor should see that all trades involved with both the VAV terminals and the electronic controls (including thermostats) have a copy of the documentation and submitted control sequence data prior to installation.

2.3 Thermostat Mounting

Thermostats may be shipped separately from the terminal units, or located inside the control enclosure as per your local sales representative's request. The thermostat may be mounted directly to drywall or optionally to a horizontally mounted, single gang junction box.

2.3.1 Drywall Mounting 2.5" x 3.5" Thermostat (Figures 6 and 7)

- a. Drill holes in wall for cable from controller and two wall anchors. Insert wall anchors in wall.
- b. Run cable through L-shaped hole in thermostat base and fasten base to wall with screws provided as shown in sketch.
- c. Mount PC Board on base so setpoint dial is at bottom between board and base (exposed setpoint unit) or at top (standard unit). Use guide pins to align. Fasten PC board to base using plastic retaining pins provided.
- d. Snap cover onto base, making sure the vertical slots are on left side (Enviro-Tec® is right side up).

2.0 INSTALLATION

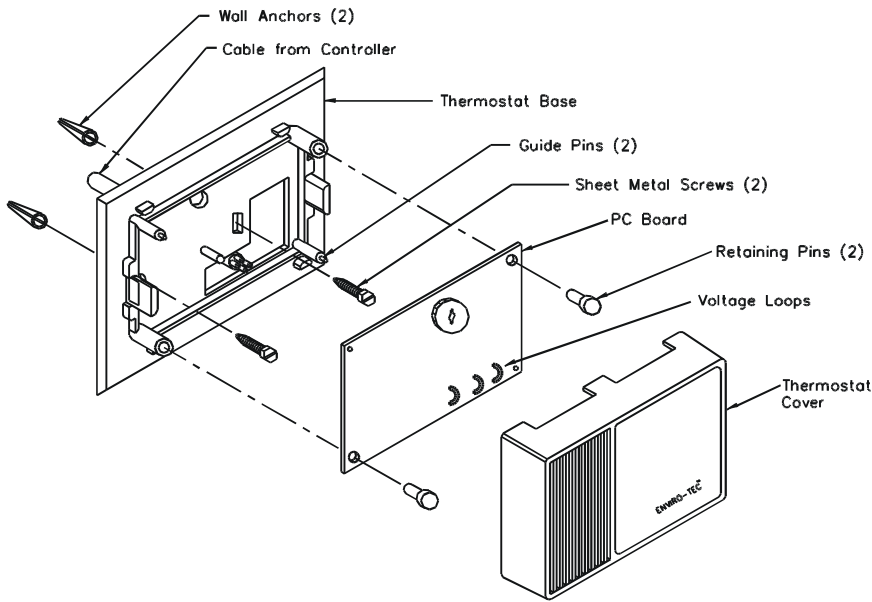

**Drywall Mounting, 2.5" x 3.5"
Standard Setpoint
(Figure 6)**

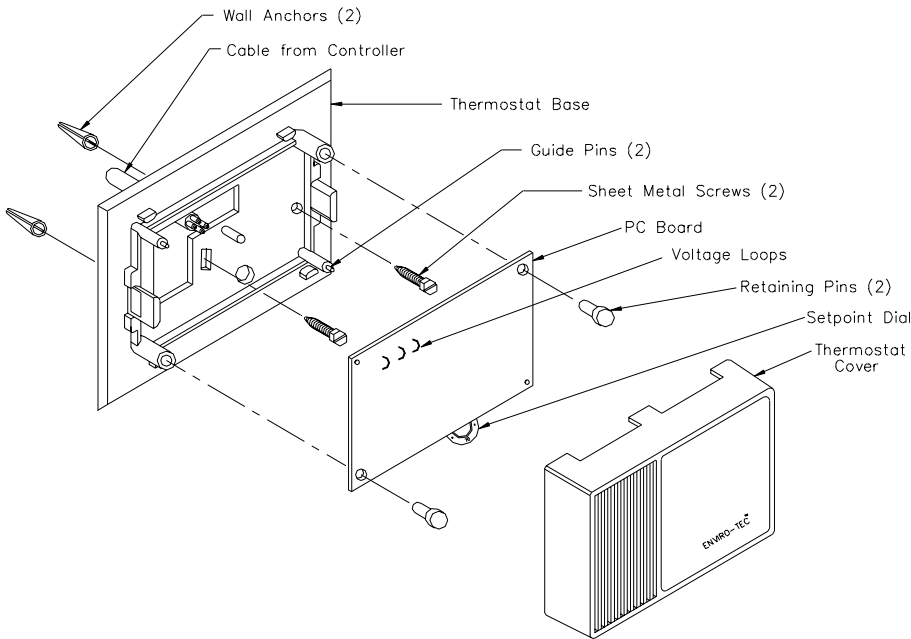

**Drywall Mounting, 2.5" x 3.5"
Exposed Setpoint
(Figure 7)**

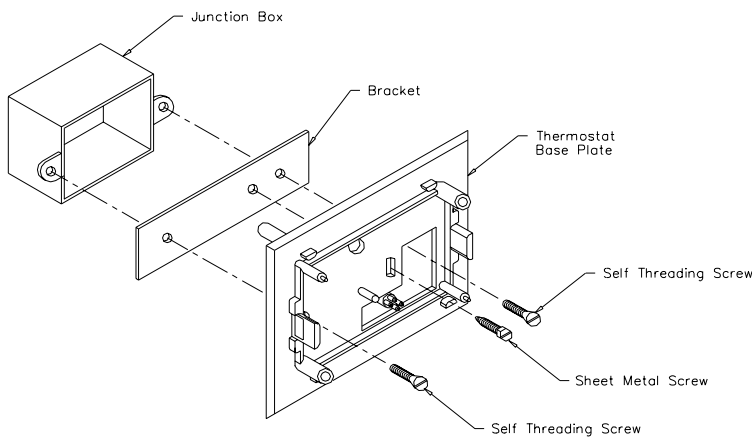

**Single Gang Junction Box
Mounting, 2.5" x 3.5"
(Figure 8)**

2.3.2 Single Gang Junction Box Mounting 2.5 x 3.5" Thermostat (Figure 8)

- Install right-hand (self-threading) screw first, (left-hand for exposed setpoint thermostat) through bracket and fix bracket to junction box.
- Install left-hand, (self-threading) screw second (right-hand for exposed setpoint thermostat) through thermostat base plate and bracket into junction box. Do not tighten fully.
- Install center sheet metal screw through thermostat base plate and bracket.
- Tighten all three screws and mount circuit board on base per 2.31c.
- Snap cover onto base, making sure Enviro-Tec® is right side up.

2.3.3 Drywall Mounting 2" Thermostat (Figure 9)

- Drill a 1 3/8" hole for the wire-mounting block on the back of the thermostat to fit into the wall.
- Hold the thermostat on the wall with the mounting block in the hole drilled, and mark the location of the two holes to either side of the center hole. **CAUTION — DO NOT DRILL THE HOLES WITH THE STAT ON THE WALL!**
- Remove the stat, drill two 3/16" holes, and insert the wall anchors.
- Connect the wires to the appropriate terminals according to the wiring diagram. Be sure to connect the jumper wire from terminal 3 to terminal 1, if required.
- Position the thermostat on the wall. Fasten the thermostat with the two 6-20x1" sheetmetal screws and insulated washers provided.
- For exposed setpoint (optional) stats, turn the setpoint potentiometer to the desired temperature and place the setpoint knob onto the setpoint potentiometer with the temperature marking at the top of the dial.
- Snap the cover back in place with the Enviro-Tec® logo at the bottom of the stat.

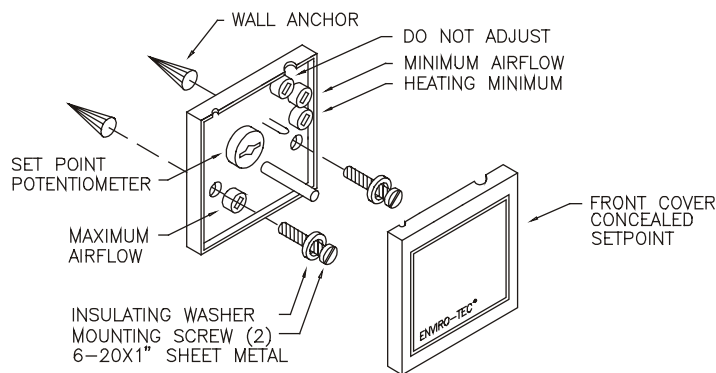

Drywall Mounting, 2" Thermostat (Figure 9)

2.3.4 Single Gang Junction Box Mounting 2" Thermostat (Figure 10)

- To mount the junction box cover horizontally break out tab "B", vertically break out tab "A".
- Attach the 2" stat to the junction cover with the two 6-32x1/2" round head screws, nuts, washers and insulation washers provided.
- Connect the wires to the appropriate terminals according the wiring diagram. Be sure to connect the jumper wire from terminal 3 to terminal 1 as required.
- Mount the cover to the junction box using the two 6-32x1/2" counter sunk screws provided.
- For (optional) exposed setpoint stats, turn the setpoint potentiometer to the desired temperature and place the set point knob onto the setpoint potentiometer with the temperature marking at the top of the dial.
- Snap the cover back in place with the Enviro-Tec® logo at the bottom of the thermostat.

2.0 INSTALLATION

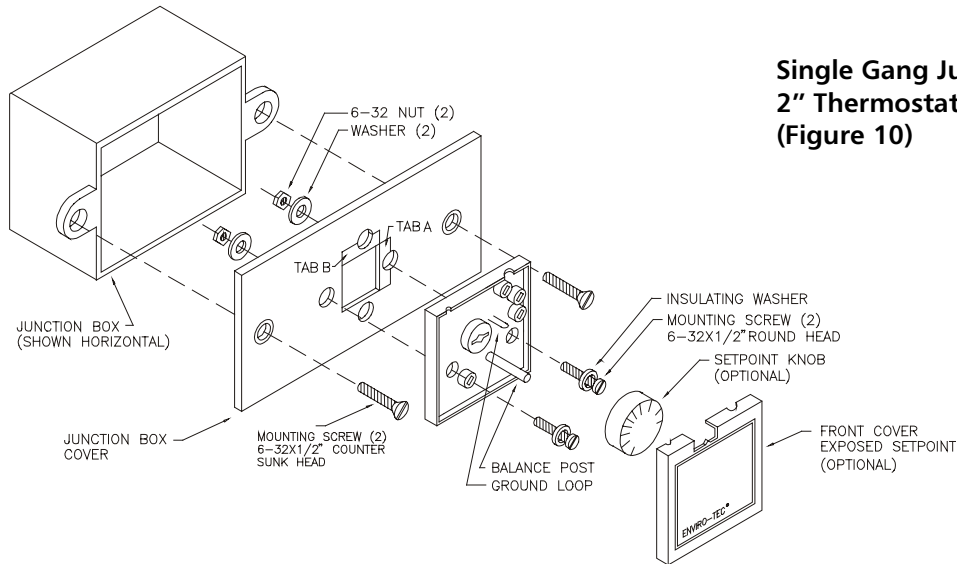

Single Gang Junction Box Mounting,
2" Thermostat
(Figure 10)

2.4 Wiring Installation

Warning – Disconnect all power supplies to the system before wiring to avoid damage to the equipment or possible electrical shock.

- Recommended wire type for external control connections is 18 to 20 AWG stranded copper.
- Wiring Diagrams – Refer to Enviro-Tec® Submittal Data (installed in the control enclosure cover on later models) to determine correct terminals for wiring. Prior to wiring, ensure that the submittal sequence matches the control model number. (Refer to Parts List in Section 6). Obtain submittal data (control sequence wiring diagram) from sales representative.
- Control wiring to thermostat and optional remote contact closures should not be routed close to AC power (line voltage) wiring, electrical machinery, or lighting to reduce the possibility of electrical interference.

2.5 Controller Wiring

- Thermostat and Control Input Connections:

- Using a small screwdriver, turn screw fully CCW.
- Strip 1/4" of insulation and insert into connector (Figure 11).
- Turn screw fully CW. Make sure connector clamps uninsulated portion of wire. Do not overtighten.

- 24 VAC Input and Control Output Connections:

- Strip 1/2" of insulation from 18-20 AWG stranded copper wire.
- Attach a 1/4" quick connect spade type receptacle to the uninsulated portion of the wire using a set of crimpers.
- Push receptacle over spade and printed circuit board. **Caution: Fit is tight.** Wiggling or pulling off with pliers may damage board. If removal of a connector is required, pry off with screwdriver, supporting PC board with your fingers.

Screw Terminal Connector
(Figure 11)

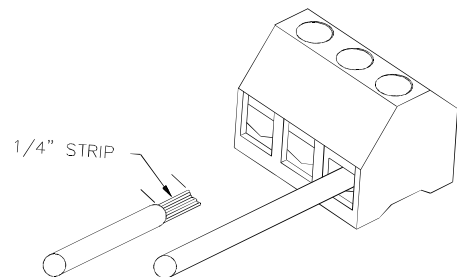

2.6 Thermostat Wiring

2.6.1 2.5" x 3.5" Thermostat

- a. Remove cover from thermostat. If a locking cover has been provided, a 1/16" allen wrench will be required to remove the two allen screws which lock the cover in place.
- b. Remove printed circuit board from base. If plastic retaining pins are tight, pry up the pins with a small screwdriver. **Caution:** Take care not to damage components on printed circuit board when prying out plastic retaining pins.
- c. Strip 1/4" of insulation from the wire.
- d. Insert wire in connector and tighten screw. **Caution:** Do not overtighten screws. Make sure connector clamps the uninsulated portion of wire.
- e. Repeat Steps C and D for all wire and terminals.
- f. Replace board on base using guide pins to align. Insert plastic retaining pins into large holes in printed circuit board and push through into base.
- g. Replace cover, making sure vertical openings on face are positioned on left side. If the cover is locking, reinsert allen screws removed in Step A so that cover cannot be removed.

2.6.2 2" Thermostat

- a. If thermostat has already been mounted to wall, remove it. Terminal numbers are engraved on back of thermostat above and below two row, six position barrier terminal block.
- b. Strip 5/16" insulation from wire.
- c. Insert wire under terminal retainer. Make sure retainer clamps bare wire, not insulation.
- d. Repeat Steps B and C for all wires shown connected in application submittal data diagram. If diagram shows a wire from controller connected to Terminal 3, remove factory installed jumper wire. Otherwise, attach bare end of factory installed jumper to Terminal 1.

CAUTION: ALWAYS VERIFY THAT WIRING IS CORRECT BEFORE APPLYING POWER.

3.0 START-UP AND BALANCE PROCEDURE

3.0 START-UP AND BALANCE PROCEDURE

3.0.1 Required Items

- a. 1/8" flat blade screwdriver
- b. Digital voltmeter capable of reading to the hundredths place and capable of reading 30 Volts AC/DC
- c. Airflow Calibration Curves (Figure 13 or 15, pages 30 & 31)

3.0.2 Optional Items

- a. Test Clips for voltmeter (Figure 12)
- b. Magnehelic or manometer (optional) with a full scale reading of 0 " – 2.0" W.G.

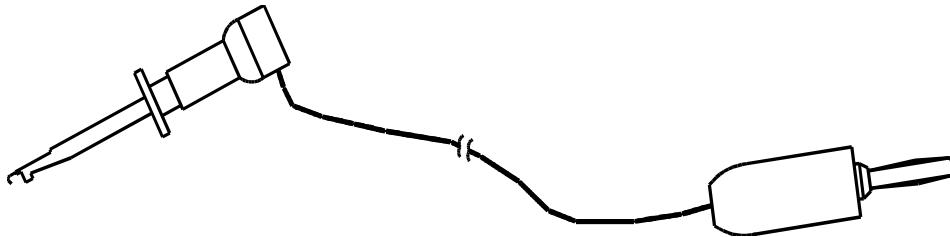

Test Clip (Figure 12)

3.1 Initial Start-up Procedure

The following items must be checked before beginning the air balancing procedure.

- a. **Verify 2.5 x 3.5" stat or 2 x 2" thermostat prior to balancing**
- b. Inspect all electrical connections to ensure proper fit and location, in accordance with the wiring diagram. Transformer leads carry a high voltage on the primary windings and associated terminals. Lethal voltages may be present.
- c. Check primary voltage to the control transformer (if applicable). Check that the output voltage is between 22 and 28 VAC. If outside these limits, remove power immediately and determine the cause of improper power. (See Troubleshooting – Section 4.0.)
- d. Check for primary airflow or static pressure if the damper is closed, in the inlet duct.
- e. ***The unit should be checked for proper sequence response before attempting to balance system. Refer to Enviro-Tec® submittal data located in control enclosure cover in later models. Contact your Enviro-Tec® sales representative if submittal data is not available.***
- f. Room temperature must be between 65° and 85°F.
- g. For optimum control accuracy, a straight section of duct at least 1.5 duct diameters long and the same diameter as the inlet collar should be installed upstream of the terminal inlet.

Minimum airflow must always be set first.

3.2 Initial Checks

- a. **2.5 x 3.5" Thermostat** - Most adjustments are made at the thermostat; however, some sequences of operation may require additional adjustments at the terminal unit. Remove the thermostat cover as previously described in Section 2.6.1. Flow adjustments (blue potentiometers) are located on the underside of the thermostat circuit board and to the left (Figure 1). Temperature adjustments are located on the front side (Figure 1). Test loops along the bottom side of the thermostat board (Figure 1) are used for measuring various voltages during the balancing procedure. Check Table 3.1 to determine which test loop to use. Always connect the black (common) clip lead to the wire marked TP1 located just below the connector labeled "2."

- b. **2" Thermostat** - Most adjustments are made at the thermostat; however, some sequences of operation may require additional adjustments at the terminal unit. Remove the thermostat cover by pushing firmly on one side (not top or bottom) of cover and pulling other side of cover away from base. Figure 1a shows location of flow and temperature setpoint adjustments. If applicable, make sure unit is in cooling and/or day mode. If this is not the case, the unit may be forced into cooling by removing the duct sensor wire attached to terminal 3 on the controller, and/or forced into day mode by removing the pressure switch wire from terminal 1 or terminal 4 (whichever is applicable). To read the calibration voltage (VSP), connect the red (+) lead of the voltmeter to the balance post under the temperature setpoint potentiometer, and the black (-) lead of the voltmeter to the wire loop (common) shown in Figure 1a.

3.3 Air Balancing Procedures for 2.5 x 3.5" Stat (Sequences ending in "R" & "A") and 2" Stat (Sequences ending in "S")

For model #'s SSD, CVF, VVF, SDD, use flow chart (Figure 15) for the linear probe.

For model #'s SDR, CFR, VFR, DDR, use flow chart (Figure 13) for the FlowStar™ probe.

The procedures described below use voltage-flow setpoints for setting airflow rates for each size unit. The curves provided in this manual (Figures 13, 14 and 15) allow setting of maximum and minimum volume to design air limits. The pressure signal from the inlet sensors can be used to verify flows and assist in the system balancing. Connect a magnehelic, inclined manometer or other differential pressure measuring device to the balancing taps provided (Figure 5). The pressure differential between high and low represents the sensed velocity pressure amplified in the inlet duct.

3.3.1 Air Terminal Units

- a. Remove thermostat cover as previously described in Section 2.6.1.a (2.5" x 3.5" thermostat) or Section 3.2.b (2" thermostat).
- b. On 2.5" x 3.5" thermostat, refer to Table 3.1 and remove wire on terminal 3 as required. On the 2" thermostat, turn the potentiometer labeled "AUX" fully clockwise. **Do not remove wire on terminal 3 of 2" thermostat.**
- c. Use the airflow calibration curves (Figures 13 and 15) to determine the balance (VSP) voltages required for the desired minimum and maximum airflow settings. For example, if a minimum CFM value of 200 is desired for a 6" SDR box, the corresponding voltage is 9.4 VDC.
- d. For control sequences SD713 through SD718 with "A" or "R" suffix (2.5" x 3.5" thermostat), go to Step I. Otherwise, continue to Step E.
- e. Turn the temperature setpoint to full heating. Adjust the potentiometer labeled "MIN" (2" thermostat) or the top blue potentiometer (2.5" x 3.5" thermostat), to the desired minimum airflow voltage.
- f. Turn the temperature setpoint to full cooling. Adjust the potentiometer labeled "MAX" (2" thermostat) or the bottom blue potentiometer (2.5" x 3.5" thermostat), to the desired maximum airflow voltage.
- g. For control sequences SD713 through SD718S (2" thermostat), turn temperature setpoint to full heating and adjust potentiometer labeled "AUX" to the desired heating minimum.
- h. Sequences SD701-704 (all suffixes), SD713-SD716 (all suffixes) and FV701-704S are now balanced. For all other control sequences go to Step K.
- i. Turn the temperature setpoint to full cooling. Adjust the top blue potentiometer to the desired minimum airflow voltage. Adjust the bottom blue potentiometer to the desired maximum airflow voltage.
- j. Turn the temperature setpoint to full heating. Adjust the middle blue potentiometer to the desired heating minimum airflow voltage. Go to Step H.
- k. Find the category below applying to the control sequence being balanced.

3.0 START-UP AND BALANCE PROCEDURE

Table 3.1

Control Sequence Charts

SSD & SDR SINGLE DUCT TERMINALS					
Sequence Number	Balance Test Loop	Morning Warm-up	Remove Wire #3	Change Over	Dual Min
SD701R	3	No	No	No	No
SD702R-4R	5	No	No	No	No
SD705R	4	Yes	Yes	No	No
SD706R-8R	5	Yes	Yes	No	No
SD709R	4	No	Yes	Yes	No
SD710R-12R	5	No	Yes	Yes	No
SD713R-15R	5	No	No	No	Yes
SD716R-18R	5	Yes	Yes	No	Yes

CFR, CFRQ, CVF & CVFQ FAN TERMINALS					
Sequence Number	Balance Test Loop	Night Setback	Remove Wire #3	Night Mode	Morning Warm-up
FC701R-4R	5	No	No	Yes	No
FC705R-8R	5	Yes	Yes	No	No
FC709R	3	No	No	No	No
FC710R-12R	5	No	No	No	No
FC713R-16R	5	No	Yes	Yes	Yes
FC717R-20R	5	Yes	Yes	No	Yes

VFR & VVF FAN TERMINALS					
Sequence Number	Balance Test Loop		Morning Warm-up	Remove Wire #3	Night Setback
	Cool	Fan			
FV701R-4R	5	4	No	No	No
FV705R-8R	5	4	No	Yes	Yes
FV709R-12R	5	4	Yes	No	No
FV713R-16R	5	4	Yes	Yes	Yes
FV717R-20R	5	4	Yes	Yes	No
FV721R-24R	5	4	Yes	Yes	Yes

NOTE: The above tables also apply to "A" sequence (SD701A) and older control sequences (SD701).

3.3.2 Model VVF-II/VFR Units with the 2.5 x 3.5" stat

- a. Move the (+) lead of your digital voltmeter to Balance Post number 4.
- b. Refer to the Airflow Calibration Curves to determine what voltage corresponds to the start/stop CFM desired (i.e., a fan start/stop CFM setpoint of 250 is desired for a box Size 6, the corresponding voltage is 8.1 VDC).
- c. With the information attained on Step b, adjust the middle potentiometer on the side of the stat until your digital voltmeter reads the desired fan start/stop CFM voltage.
- d. **NOTE:** Adjust the fan start/stop potentiometer fully CCW if you want the fan to start and stop based on temperature demand instead of CFM.
- e. Reconnect wire to terminal 3 of the thermostat.

3.3.3 Sequences SD705R-SD712R, SD716R-SD718R, FC713R-FC720R, FV717R-FV724R

- a. If applicable, reconnect wire to terminal 3 of thermostat.
- b. Adjust the blue potentiometer on the controller labeled "Duct Sensor" to a temperature midway between the expected cold and warm air temperatures. Recommended minimum difference in cold and warm air temperature is 10°F.

3.3.4 All Series Flow Fan Terminals (Models CFR, CFRQ, CVF, CVFQ)

- a. These terminals need the fan speed adjusted so that when drawing maximum primary airflow, no air is either entering or leaving the plenum air inlet. Turn temperature setpoint to full cooling, and wait for damper to move to maximum CFM setpoint.
- b. A three speed switch or a motor speed adjustment terminal strip is used in conjunction with an electronic fan speed controller to make this adjustment. Locate these components in the terminal's control or electric heat enclosure. A hole in the front cover of the fan speed controller allows adjustment using a small screwdriver. Verify the adjustment is fully CW.

CAUTION: LETHAL VOLTAGES ARE PRESENT!

- If a motor speed adjustment terminal strip is provided instead of a three speed switch, disconnect all power before attempting to adjust or change motor speed terminals.
 - Do not adjust the fan speed controller using your hand.
 - Do not touch the back of the fan speed controller.
 - Do not adjust the second, factory set potentiometer, only accessible from the back, or warranty will be voided.
- c. If air is leaving the plenum air inlet, go to Step 3.3.4.d. Otherwise, go to Step 3.3.4.g.
 - d. Adjust three speed switch to "Med" or remove power, then remove end of jumper connected to "Low Spd" terminal and reinstall on the "Med Spd" terminal.
 - e. If removed, re-apply power. If air is leaving the plenum air inlet, go to Step 3.3.4.f. Otherwise, go to Step 3.3.4.g.
 - f. Adjust three speed switch to "High", or remove power, then remove end of jumper connected to "Med Spd" terminal and reinstall on the "High Spd" terminal. Re-apply power.
 - g. Using the hole in the front cover of the fan speed controller and a small screwdriver, slowly adjust CCW so that no air is either entering or leaving the plenum air inlet.

3.0 START-UP AND BALANCE PROCEDURE

3.3.5 Dual Duct DD701R and DD701S

- a. Dual Duct sequences have the air flow adjustments on the controller board instead of the thermostat. Disregard all statements that refer to the airflow adjustments on the thermostat. The same flow curves are used to set CFM.
- b. Connect the red (+) lead from the DC voltmeter to the VSP test loop and the black (-) lead to the Com test loop on the cold deck controller (ETPD0U).
- c. Turn the temperature setpoint potentiometer on the thermostat to full heating and the R143 potentiometer on the cold deck controller, fully clockwise. On the cold deck controller (ETPD0U), adjust R150 until the voltmeter reads 17 VDC. Move the test leads from the cold deck controller to the VSP loop and the Com loop on the hot deck controller (ETPD0HU). Adjust R143 on the hot deck for the desired maximum CFM voltage.
- d. Turn the temperature setpoint potentiometer on the thermostat to full cooling and the R143 potentiometer on the hot deck controller fully clockwise. On the hot deck controller, adjust R150 until the meter reads 17 VDC. Move the test leads back to the VSP test loop and the Com test loop on the cold deck controller. Adjust R143 on the cold deck to the desired maximum CFM voltage.

3.3.6 Dual Duct DD702R

- a. Connect the red (+) lead from a DC voltmeter to the VSP test loop and the black (-) lead to the Com test loop on the cold deck controller (ETPD0U).
- b. Turn the cooling setpoint potentiometer on the thermostat to full heating, and the R143 on the cold deck controller, fully clockwise. Adjust R150 on the cold deck until the voltmeter reads 17 VDC. Turn the temperature setpoint potentiometer on the thermostat to full cooling and adjust R150 on the cold deck controller until the meter reads the desired maximum CFM voltage.
- c. Move the test leads from the cold deck controller to the hot deck controller, the red (+) lead on the VSP test loop and the black (-) test lead on the Com test loop.
- d. Turn the heating setpoint potentiometer on the thermostat fully counter clockwise and R143 on the hot deck controller fully clockwise. Adjust R150 on the hot deck controller until the voltmeter reads 17 VDC. Turn the heating setpoint potentiometer fully clockwise and adjust R143 on the hot deck controller to the desired maximum CFM voltage.

4.0 TROUBLESHOOTING

WARNING: WITH ALL ELECTRICAL DEVICES THERE IS DANGER OF ELECTRICAL SHOCK. LETHAL VOLTAGES ARE PRESENT AT THE SUPPLY CONNECTIONS OF ALL POWER TRANSFORMERS. USE CAUTION WHEN MEASURING OPERATING VOLTAGES OF THESE UNITS.

- a. At the beginning of each section are "Common Problems." To save time, check these items first.
- b. Many of the procedures refer to Normal and/or Option Mode. Normal Mode refers to daytime, cooling operation. A unit with options may be forced into Normal Mode by removing the duct sensor wire from terminal 3, and/or removing a wire from the pressure switch.
- c. Many of the procedures in this section require taking voltage readings. This may be done easily by using meter leads with spring-loaded clips instead of the usual probes. These leads free your hands for other work; they may be purchased at consumer electronics stores. For controller terminals not having test loops, voltages may be read by holding the meter lead directly on the screw terminal or tab connector (as applicable). Test points followed by a "(+)" are to be attached to the "+" jack of your meter, which is usually the red lead. Test points followed by a "(-)" are to be attached to the "-" jack of your meter, which is usually the black lead.
- d. Since most of the procedures are temperature related, you must ensure that the ambient temperature at the thermostat is 55-85°F. Also, the primary air supply must be 55-85°F, with 0.5-2.5" W.G. inlet static pressure.
- e. Some procedures require the balancing voltages to be changed for test purposes. It is a good idea to record these so they may be restored after troubleshooting is complete.
- f. The following table is a list of unit functions. Follow the table **in the order presented** to determine the specific problem(s). For instance, to diagnose a single duct, cooling only terminal which does not move its damper when the thermostat is turned from full heating to full cooling (or vice versa), first go through Section 4.1 (Damper Motion), then 4.9 (No Response to Thermostat).

Table 4.0 – Quick Reference	
Problem With	Proceed to Section
Damper Motion	4.1
Fan	4.2
Electric or Hot Water Heat	4.3
Night Setback	4.4
Night Mode	4.5
Morning Warm-up	4.6
Auxiliary Minimum	4.7
Changeover	4.8
Airflow Readings	4.9
No Response to Thermostat	4.10
Corrective Actions	4.11

4.0 TROUBLESHOOTING

4.1 Damper Motion

NOTE: The current 700 Series Controller drives a DC actuator motor or an ACT24 Actuator in conjunction with an ETAC DC to AC actuator drive interface. Since the output is time-proportioned, it may be necessary to observe the actuator for up to 30 seconds before proceeding with each step.

COMMON PROBLEMS

- Output wires backwards.
- Option mode is enabled; verify the unit is in Normal Mode before continuing with this procedure.

Step	Action	Result	Proceed To
4.1.1	Set the MIN (and AUX MIN, if equipped) airflow to 17 VDC per Section 3.0, "Balancing"	Good Bad	4.1.2 4.10
4.1.2	Set maximum airflow to 5.0 VDC	Good Bad	4.1.3 4.10
4.1.3	Connect DC voltmeter between Vsp (+) and Com (-) test loops on controller. Vary thermostat setpoint "A" and verify the voltage goes from 17 VDC to 5.0 VDC.	Good Bad	4.1.4 4.11.1
4.1.4	Disconnect both air hoses at the sheet metal enclosure entrance and verify voltage between Vf (+) and Com (-) test loops on controller is between 14.5 – 17 VDC.	Good Bad	4.1.5 4.9
4.1.5	Turn temperature setpoint ("A" if dual setpoints) to full cooling. Verify damper shaft rotates CCW (open).	Good Bad	4.1.6 4.1.9
4.1.6	Turn temperature setpoint ("A" if dual setpoints) to full heating. Attach hose from "high" side of airflow probe to transducer port on controller labeled high. Verify voltage between VF (+) and Com (-) test loops on controller measures between 0-8 VDC.	Good Bad	4.1.7 4.9
4.1.7	Turn temperature setpoint ("A" if dual setpoints) to full heating. Verify damper shaft rotates CW (closed)	Good Bad	4.1.8 4.1.9
4.1.8	Damper actuator controls are working correctly. If you have other problems, refer to Table 4.0		
4.1.9	If damper actuator is an ACT24, determine if it is functional according to the Checkout Instructions of attached ACT24 IOM. Otherwise, go to Step 4.1.10	Good Bad	4.11.3 4.11.13
4.1.10	Measure voltage between actuator terminals with the red (+) lead on terminal with red dot. If voltage is less than +/- 1 VDC, go to Step 4.1.11. If voltage is between +1 and +3 VDC, go to Step 4.1.12. If voltage is between -1 and -3 VDC, go to Step 4.1.13.		
4.1.11	Disconnect actuator wires and check for +/- 10 to 16 VDC between terminals 13 and 14 of controller.	Good Bad	4.11.13 4.11.3
4.1.12	Controller is driving actuator open, but actuator is stalled. If actuator is against either the damper's mechanical stop or its own mechanical stop, go to Step 4.1.14. Otherwise, replace actuator.		
4.1.13	Controller is driving actuator closed, but actuator is stalled. If actuator is against either the damper's mechanical or its own mechanical stop, go to Step 4.1.14. Otherwise, replace actuator.		
4.1.14	Reverse the actuator wires to move the actuator off the stop. Place the wires back in the original position and verify the actuator moves back against the stop.	Good Bad	4.11.3 4.11.13

4.2 Fan

NOTE: On VVF-II/VFR terminals, the fan relay is controlled by the electronic controller in Normal (day) Mode. It is engaged according to either primary airflow or ambient temperature, depending on the control sequence and balance settings.

On CVF-II/CFR terminals, the fan relay is kept on in Normal Mode. In the Option Mode, the fan is cycled to either maintain temperature or off, depending on your sequence.

COMMON PROBLEMS

- Blown fan motor fuse.
- Option Mode is enabled, verify unit is in Normal Mode.
- Fan start/stop potentiometer (VVF-II/VFR models) misadjusted.
- Blue and yellow wires swapped between transformer and controller.

Table 4.2

Step	Action	Result	Proceed To
4.2.1	If the unit in question is VVF-II/VFR If the unit in question is CVF-II/CFR		4.2.2 4.2.9
4.2.2	Turn the fan start/stop (middle blue) potentiometer on the thermostat fully CCW.		
4.2.3	Connect DC voltmeter between Test Point 6 (+) and TP1 (-) on thermostat. Vary thermostat setpoint "A" and verify voltage goes from approximately 1VDC (CCW) to 17 VDC (CW).	Good Bad	4.2.4 4.10
4.2.4	Connect DC voltmeter between terminal 5 (+) and Com (-) on controller. Vary thermostat setpoint "A" and verify voltage goes from approximately 1VDC (CCW) to 17 VDC (CW).	Good Bad	4.2.5 4.11.1
4.2.5	Locate the fan relay/contacter. It is installed in either the control or heater enclosure.		
4.2.6	Turn thermostat setpoint ("A" if dual setpoints) to full cooling, then slowly turn it to full heating, verify the fan relay/contacter engages at 1 to 2° above ambient temperature.	Good Bad	4.2.10 4.2.7
4.2.7	Carefully check wiring to the fan relay/contacter per the sequence.	Good Bad	4.2.8 4.11.1
4.2.8	Remove the wire from controller terminal 9 and touch it briefly to terminal 15. Verify the fan relay/contacter engages.	Good Bad	4.11.3 4.11.4
4.2.9	Locate the fan relay/contacter installed in enclosure. Verify the relay is engaged.	Good Bad	4.2.8 4.2.7
4.2.10	Fan controls are operating correctly in normal mode. To test the fan in an option mode or you have other problems, refer to Table 4.0.		

4.0 TROUBLESHOOTING

4.3 Electric or Hot Water Heat

COMMON PROBLEMS

- Blown fan motor fuse.
- Option mode is enabled; verify the unit is in Normal mode.
- Blue and yellow wires swapped from transformer to controller.

Step	Action	Result	Proceed To
4.3.1	Connect DC voltmeter between test point 6 (+) and TP1 (-) on thermostat. Vary thermostat setpoint "A" and verify voltage goes from approximately 1 VDC (CCW) to 17 VDC (CW).	Good Bad	4.3.2 4.10
4.3.2	Connect DC voltmeter between controller terminal 5 (+) and Com (-). Slowly turn thermostat setpoint ("A" if dual setpoints) from heating to cooling and verify voltage goes from approximately 1 VDC (CCW) to 17 VDC (CW).	Good Bad	4.3.3 4.11.1
4.3.3	Locate the heat relay(s) or contactors		
4.3.4	Turn thermostat setpoint ("A" if dual setpoints) to full cooling, slowly turn to heating. Verify the heat 1 relay/contacter engages at 2-3° above ambient temperature.	Good Bad	4.3.5 4.3.6
4.3.5	If you have only one stage of electric heat, go to 4.3.6. Continue slowly turning ("A" if dual setpoints) to heating and verify heat 2 and 3 engage in 1° increments.	Good Bad	4.3.7 4.3.6
4.3.6	Check wiring to the heat relays/contactors per the wiring diagram. If correct, remove the wire from terminal output (10 through 12), and briefly touch it to terminal 15. Verify the heat relay/contacter engages.	Good Bad	4.11.3 4.11.5
4.3.7	Heat controls are operating correctly in Normal Mode. To test the heat in an option mode or you have other problems, refer to Table 4.0.		

4.4 Night Setback

COMMON PROBLEMS

- Air hose on pressure switch connected to the low fitting instead of high.
- Wires on pressure switch not connected to NC and COM.
- Insufficient static pressure to keep pressure switch open.

Table 4.4

Step	Action	Result	Proceed To
4.4.1	Connect a DC voltmeter between controller terminals 1 (+) and Com (-). Verify voltage is 14-18 VDC.	Good Bad	4.4.6 4.4.2
4.4.2	Verify the wiring is correct. Remove the wire from controller terminal 1 and verify voltage from terminal 1 (+) to Com (-) is 14-18 VDC.	Good Bad	4.4.3 4.11.3
4.4.3	Disconnect the air hose to the pressure switch, reconnect the wire to terminal 1 and verify the voltage from controller terminal 1 (+) to Com (-) is 0-1 VDC.	Good Bad	4.4.4 4.11.6
4.4.4	Blow in the hose and verify the voltage from controller terminal 1 (+) to Com (-) jumps up to 14-18 VDC.	Good Bad	4.4.5 4.11.6
4.4.5	Verify primary static pressure is above 0.3" W.G.	Good Bad	4.11.6 4.11.7
4.4.6	Disconnect the air hose to the pressure switch. Verify voltage is 0-1 VDC.	Good Bad	4.4.7 4.4.2
4.4.7	Connect voltmeter from controller terminal 2 (+) to Com (-) and verify 0-1 VDC.	Good Bad	4.4.8 4.11.3
4.4.8	Reconnect air hose to pressure switch. Verify voltage is 14-18 VDC.	Good Bad	4.4.9 4.11.3
4.4.9	Connect voltmeter between thermostat terminal 3 (+) and TP1 (-). Verify voltage is 14-18 VDC.	Good Bad	4.4.10 4.11.1
4.4.10	Disconnect air hose from pressure switch. Verify voltage is 0-1 VDC.	Good Bad	4.4.11 4.11.1
4.4.11	If the sequence uses a 2.5" x 3.5" stat, vary temperature setpoint "B" and verify it turns the fan on/off. If the sequence uses a 2" stat, turn the temperature setpoint 5°F above room temperature and vary the offset potentiometer (R107 on the controller) and verify it turns the fan on/off.	Good Bad	4.4.12 4.11.8
4.4.12	Reconnect air hose and vary temperature setpoint ("A" if dual setpoints), verify it controls the damper.	Good Bad	4.4.13 4.11.8
4.4.13	Night Setback is operating correctly. To test controls in an option mode or if you have other problems, refer to Table 4.0.		

4.0 TROUBLESHOOTING

4.5 Night Mode

COMMON PROBLEMS

- Air hose on pressure switch connected to LOW fitting instead of HIGH.
- Wires on pressure switch not connected to NC and COM.
- Insufficient static pressure to keep pressure switch open.

Step	Action	Result	Proceed To
4.5.1a	If the unit in question is FC701A-FC704R		4.5.2
4.5.1a	If the unit in question is FC713A-FC716R		4.5.10
4.5.2	Verify voltage between controller terminals 4 (+) and Com (-) is 14-18 VDC.	Good Bad	4.5.7 4.5.3
4.5.3	Verify air pressure switch and controller wiring is correct. Remove the wire from controller terminal 4 and verify voltage from terminal 4 (+) to Com (-) is 14-18 VDC.	Good Bad	4.5.4 4.11.3
4.5.4	Temporarily disconnect the hose going to the pressure switch. Reconnect the wire to terminal 4, and verify voltage from controller terminal 4 (+) to Com (-) is 0-1 VDC.	Good Bad	4.5.5 4.11.6
4.5.5	Blow in the hose going to airflow switch and verify voltage increases to 14-18 VDC.	Good Bad	4.5.6 4.11.6
4.5.6	Verify primary static pressure above 0.3" W.G.	Good Bad	4.11.6 4.11.7
4.5.7	Remove air hose from pressure switch, verify voltage is 0-1 VDC.	Good Bad	4.5.8 4.5.3
4.5.8	Turn thermostat setpoint ("A" if dual setpoints) to full heating. Verify fan (and heat, if applicable) are off.	Good Bad	4.5.9 4.11.3
4.5.9	Reconnect air hose. Verify fan (and heat, if applicable) are on.	Good Bad	4.5.13 4.11.3
4.5.10	Turn duct sensor potentiometer on controller fully CW. Connect a DC voltmeter between controller terminals 1 (+) and com (-). Verify voltage is 14-18 VDC	Good Bad	4.5.7 4.5.11
4.5.11	Verify the air pressure switch and controller wiring are all correct. Remove the wire from controller terminal 1 and verify voltage from terminal 1 (+) to Com (-) is 14-18 VDC.	Good Bad	4.5.12 4.11.3
4.5.12	Temporarily disconnect the hose going to the pressure switch. Reconnect the wire to terminal 1 and verify the voltage from controller terminal 1 (+) to Com (-) is 0-1 VDC.	Good Bad	4.5.5 4.11.6
4.5.13	Night Mode is operating correctly. If you wish to test the controls in an option mode or you have other problems, refer to Table 4.0.		

4.6 Morning Warm-Up (Control Sequences FV721 – 724A, R or S and FC717 – 720 A, R or S ONLY)

If sequence uses changeover version of morning warm-up, go to 4.8.

COMMON PROBLEM

- Duct Sensor Setpoint out of adjustment: this should be set midway between expected cold supply and hot supply air temperatures. In lieu of this, set it to 70°F.

Step	Action	Result	Proceed To
4.6.1	Disconnect both duct sensor wires from controller and verify duct sensor resistance is between 11 Kohms and 27 Kohms (temperature dependent: high value cool, low value warm).	Good Bad	4.6.2 4.11.9
4.6.2	Turn temperature setpoint ("A" if dual setpoints) to full heating. Force unit to day mode by removing pressure switch wire from terminal 1 or 4. Turn duct sensor potentiometer on controller fully CCW. Verify 15-18 VDC from terminal 5 to COM test loop on controller.	Good Bad	4.6.3 4.6.5
4.6.3	Turn duct sensor potentiometer on controller fully CW. Verify 0-1 VDC from terminal 5 to COM test loop on controller.	Good Bad	4.6.4 4.6.5
4.6.4	Morning Warmup is operating correctly. To test controls in another option mode or if you have other problems, refer to Table 4.0		
4.6.5	Duct sensor may be out of calibration. Attempt to calibrate using the procedure in Section 5.2.	Good Bad	4.6.4 4.11.3

4.7 Auxiliary Minimum

COMMON PROBLEMS

- Improper wiring.
- Improper balancing: read Section 3.0 carefully to properly balance a unit having Aux Min (also known as a Dual Minimum or Heating Minimum).
- Operator error: read the control sequence carefully to fully understand how Aux Min operates.
- On units having Morning Warm-up, verify warm-up is not enabled before starting this procedure.

Step	Action	Result	Proceed To
4.7.1	Turn MIN and AUX MIN potentiometers fully CCW. Turn MAX potentiometers fully CW. Turn thermostat setpoint ("A" if dual setpoints) to full cooling. Verify damper is opening.	Good Bad	4.7.2 4.10
4.7.2	Verify voltage between thermostat terminals 4 (+) and TP1 (-) is 0-1 VDC.	Good Bad	4.7.5 4.7.3
4.7.3	Carefully check wiring per control sequence.	Good Bad	4.7.4 4.11.1
4.7.4	Replace thermostat and set potentiometers as in Step 4.7.1. Verify voltage between terminals 4 (+) and TP1 (-) is 0-1 VDC.	Good Bad	4.11.8 4.11.3
4.7.5	Turn thermostat setpoint ("A" if dual setpoints) fully CW. Verify voltage between thermostat terminals 4 (+) and TP1 (-) is 14-18 VDC.	Good Bad	4.7.8 4.7.6
4.7.6	Carefully check wiring per control sequence.	Good Bad	4.7.7 4.11.1
4.7.7	Replace thermostat. Verify voltage between terminals 4 (+) and TP1 (-) is 14-18 VDC. Set potentiometers as in Step 4.7.1 and turn temperature setpoint to full heating.	Good Bad	4.11.8 4.11.3
4.7.8	Verify voltage between controller test point VSP and Com (-) is 14-18 VDC.	Good Bad	4.7.9 4.10
4.7.9	Slowly turn the AUX MIN potentiometer on the thermostat CW and verify the voltage drops.	Good Bad	4.7.11 4.7.10

4.0 TROUBLESHOOTING

Step	Action	Result	Proceed To
4.7.10	Carefully check wiring per control sequence.	Good Bad	4.11.8 4.11.1
4.7.11	Check to ensure that the heat relay(s) are all ON.	Good Bad	4.7.12 4.3
4.7.12	Slowly turn Thermostat Setpoint ("A" if dual setpoints) CCW until heat 1 relay turns off. Verify voltage between controller test point VSP & COM (-) is 14-18 VDC.	Good Bad	4.7.13 4.10
4.7.13	Slowly turn the MIN potentiometer on the thermostat CW and verify the voltage drops.	Good Bad	4.7.14 4.10
4.7.14	Adjust the MIN potentiometer to 17 VDC. Turn the thermostat setpoint ("A" if dual setpoints) to full heating and adjust the AUX MIN potentiometer to 13.0 VDC. Turn the thermostat setpoint ("A" if dual setpoints) to full cooling and adjust the MAX potentiometer to 5.0 VDC.	Good Bad	4.7.15 4.7.10
4.7.15	Verify the damper opens, then modulates at its MAX position (which was set in the above step).	Good Bad	4.7.16 4.1
4.7.16	Turn the thermostat setpoint "A" fully CW and verify the damper goes to its AUX MIN position (which was set in 4.7.14).	Good Bad	4.7.17 4.10
4.7.17	Slowly turn thermostat setpoint "A" fully CCW until the Heat 1 relay turns off. Verify the damper goes almost closed; this will be the MIN position as set in 4.7.14.	Good Bad	4.7.18 4.10
4.7.18	Auxiliary Minimum is operating correctly. To test the controls in an option mode or if you have other problems, refer to Table 4.0.		

4.8 Changeover/Warm-Up (All Morning Warm-Up Sequences EXCEPT FV721 - 724 A, R or S, and FC717 - 720 A, R or S)

COMMON PROBLEM

- Duct Sensor Setpoint out of adjustment: this should be set midway between expected cold supply and hot supply air temperatures, in lieu of this set it to 70°F.

Step	Action	Result	Proceed To
4.8.1	Turn duct sensor potentiometer on controller fully CW. Connect DC voltmeter between terminals 2 (+) and 7 (-). Verify voltage is 14-18 VDC.	Good Bad	4.8.4 4.8.2
4.8.2	Verify all wiring correct between thermostat and controller, per control sequence. If correct, disconnect both duct sensor wires from controller and verify duct sensor resistance is between 11 Kohms and 27 Kohms (temperature dependent: high value cool, low value warm).	Good Bad	4.8.3 4.11.9
4.8.3	Reconnect duct sensor and remove wire from terminal 2. Turn duct sensor potentiometer on controller fully CW. Connect DC voltmeter between controller terminals 2 (+) and 7 (-). Verify voltage is 14-18 VDC.	Good Bad	4.11.8 4.8.10
4.8.4	Turn duct sensor potentiometer on controller full CCW. Connect DC voltmeter between terminals 2 (+) and 7 (-). Verify voltage is 0-1 VDC.	Good Bad	4.8.5 4.8.2
4.8.5	Turn temperature setpoint ("B" if dual setpoints) to full heating. Verify damper is opening.	Good Bad	4.8.6 4.10
4.8.6	Turn temperature setpoint ("B" if dual setpoints) to full cooling. Verify damper is closing.	Good Bad	4.8.7 4.10
4.8.7	Turn duct sensor potentiometer on controller fully CW. Turn temperature setpoint ("A" if dual setpoints) to full cooling. Verify damper is opening.	Good Bad	4.8.8 4.10
4.8.8	Turn temperature setpoint ("A" if dual setpoints) to full heating. Verify damper is closing.	Good Bad	4.8.9 4.10
4.8.9	Changeover is operating correctly. To test the controls in an option mode or if you have other problems, refer to Table 4.0.		
4.8.10	Duct sensor may be out of calibration. Attempt to calibrate using the procedure in Section 5.2.	Good Bad	4.8.9 4.11.3

4.9 Airflow Readings

COMMON PROBLEMS

- Loose tubing at velocity probe in VAV terminal inlet.
- Loose tubing at coupling (transition from black to clear tubing).
- Loose tubing at controller.
- Flex duct on inlet is bent too tightly. There should be a minimum of 1 ½ diameter of straight duct at the inlet (i.e., an 8" box would need 12" of straight duct).
- HIGH and LOW tubing connections reversed at controller.

Table 4.9

Step	Action	Result	Proceed To
4.9.1	Disconnect both airflow hoses at the duct inlet. Connect voltmeter to "Vf" (+) and Com (-). Verify 14.5-18 VDC.	Good Bad	4.9.2 4.11.3
4.9.2	Blow gently through the airflow hose connected to HIGH on the controller. Verify voltage drops to 0-3 VDC.	Good Bad	4.9.3 4.11.3
4.9.3	The flow circuit seems to be operating correctly. Carefully check the items under "Common Problems" above.	Good Bad	4.11.10 4.9.4
4.9.4	Fix tubing and/or flex duct, and go to Step 4.9.1.		

4.10 No Response to Thermostat

COMMON PROBLEMS

- Incorrect wiring; check control sequence carefully.
- Insufficient static air pressure.
- Option mode is enabled; verify that the unit is in Normal Mode before continuing with this procedure.

Table 4.10 No Response to Thermostat

Step	Action	Result	Proceed To
4.10.1	Measure AC voltage between terminals 15 and 16 at the controller. Verify 22.0-27.6 VAC.	Good Bad	4.10.2 4.11.11
4.10.2	Turn power off to the controller, remove the fuse and verify that fuse resistance is 0-1 ohm.	Good Bad	4.10.3 4.11.12
4.10.3	Reinstall the fuse in the controller and restore power. Remove the wire from controller terminal 8 and measure the voltage from terminal 8 (+) to Com (-). Verify voltage is 17.2-18.7 VDC.	Good Bad	4.10.4 4.11.3
4.10.4	Reconnect wire to terminal 8. Measure voltage between thermostat terminals 1 (+) and 2 (-). Verify voltage is 17.2-18.7 VDC.	Good Bad	4.10.5 4.11.1
4.10.5	Measure voltage between controller test point "Vf" (+) and Com (-). Verify voltage is 4-14 VDC.	Good Bad	4.10.6 4.9.1
4.10.6	Verify the unit is in normal mode by referring to the appropriate step, i.e. Night Setback, Morning Warm-up, etc., and ensure the option mode is not enabled. If your thermostat has terminal 6 installed, continue; otherwise, go to Step 4.10.9. Turn temperature setpoint "A" fully CW. Measure voltage at controller terminals 5 (+) and Com (-). Verify 16-18 VDC.	Good Bad	4.10.8 4.10.7
4.10.7	Check wiring per control sequence.	Good Bad	4.11.8 4.11.1
4.10.8	Turn temperature setpoint "A" fully CCW. Measure voltage at controller terminals 5 (+) and Com (-). Verify 0-2 VDC.	Good Bad	4.10.9 4.10.7

4.0 TROUBLESHOOTING

Table 4.10 No Response to Thermostat (continued)			
4.10.9	Identify the thermostat terminal called "Balance Post" per Table 3.1. Disconnect the wire from this terminal and connect DC voltmeter between balance post terminal (+) and TP (-).		
4.10.10	Turn temperature setpoint ("A" if dual setpoints) to full heating. Turn MIN and AUX MIN/FAN, if present potentiometer fully CCW. Verify voltage is 15-18 VDC.	Good Bad	4.10.11 4.11.8
4.10.11	Turn temperature setpoint ("A" if dual setpoints) to full cooling. Verify voltage is 0-4 VDC.	Good Bad	4.10.12 4.11.8
4.10.12	Reconnect the wire to the balance post terminal. At the controller, disconnect the wire from terminal 6 and leave hanging free. Measure the voltage between this wire (+) and Com (-) on the controller. Verify 0-4 VDC.	Good Bad	4.10.13 4.11.1
4.10.13	Turn temperature setpoint ("A" if dual setpoints) to full heating. Verify voltage is 15-18 VDC.	Good Bad	4.10.14 4.11.1
4.10.14	Reconnect the wire to terminal 6 and measure the voltage between "Vsp" (+) and Com (-). Verify voltage is 15-18 VDC.	Good Bad	4.10.15 4.11.3
4.10.15	Verify the damper is closing.	Good Bad	4.10.16 4.1.1
4.10.16	Turn temperature setpoint ("A" if dual setpoints) to full cooling. Verify the damper is opening.	Good Bad	4.10.17 4.1.1
4.10.17	The thermostat is operating correctly with regard to the damper control signal, and the fan/heat control signal. The controller is operating correctly with regard to the damper control. If you are having problems with an option mode, refer to Table 4.0.		

4.11 Corrective Actions

Table 4.11 Corrective Actions	
Step	Probable Cause / Remedy
4.11.1	Wiring is bad. Your electronic components may withstand some types of wiring errors, but not all. Check sequence, call your representative for assistance if needed before applying power. A phone call can save you time and may prevent equipment damage.
4.11.2	Damper shaft is not indexed correctly. Loosen the damper shaft bolt. Turn temperature setpoint "A" to full cooling and wait for the actuator to drive to full open (CCW) position. Open the damper by manually rotating the shaft fully CCW and retighten the bolt. Repeat Step 4.1.5.
4.11.3	Controller is potentially bad.
4.11.4	Fan relay is bad. Replace it.
4.11.5	Heat relay is bad. Replace it.
4.11.6	Air pressure switch is bad. Replace it.
4.11.7	Insufficient primary static air pressure. Check static pressure controller on main air handler and/or balancing dampers upstream, or the VAV terminal that may have swung closed, etc.
4.11.8	Thermostat is bad. Replace it.
4.11.9	Duct sensor is bad. Replace it.
4.11.10	Controller is out of calibration. Since it cannot be field calibrated, it must be replaced.
4.11.11	Transformer and/or incoming line voltage (i.e. 120 VAC, 277 VAC) is bad. Check line voltage and if OK replace transformer.
4.11.12	Fuse is blown. Replace with a standard 1 amp, 3AG fuse.
4.11.13	Actuator is bad. Replace it.

5.0 TEMPERATURE CALIBRATION, THERMOSTAT & DUCT TEMPERATURE SENSOR

5.0 Temperature Calibration

Temperature calibration is only required under special circumstances. It is not normally required during initial installation, commissioning and/or balancing.

5.1 Thermostat

All thermostats are factory calibrated in a controlled environment; however, they may occasionally become uncalibrated during shipment or installation. Also, the thermostat may not be able to be located in such a way as to accurately reflect the temperature of the majority of the space. The procedure below allows these conditions to be corrected in the field.

- a. Ensure the space temperature is between 60°F and 80°F. Remove the thermostat cover as described in Section 3.2. **CAUTION:** The temperature measuring device (thermistor) located in the lower left corner of the 2" thermostat or middle left of the 2.5" x 3.5" thermostat (see Figure 1) is very sensitive to temperature with the cover removed. Body heat can influence it greatly; therefore, attempt to keep hands away from the device while performing the procedures below.
- b. Verify that the controls are in the NORMAL (day or cooling) MODE. Determine the maximum and minimum (cooling minimum if dual minimum application) airflow voltages.
- c. Use a calibrated temperature meter or thermometer to determine the space temperature, and set the temperature setpoint ("A" if dual setpoints) to that temperature. Connect DC voltmeter between the balance post (+) of the thermostat (see Figure 1) and the common loop (-). If calibrating a 2.5" x 3.5" thermostat, go to Step G.
- d. Adjust the uppermost white potentiometer (labeled "Temperature Calibration" in Figure 1) until the voltmeter reads the maximum airflow voltage (lowest value in volts).
- e. While watching the voltmeter, SLOWLY adjust the uppermost white potentiometer until the voltage reaches minimum flow voltage (highest value in volts). The point at which the voltage reaches minimum flow voltage when adjusting from maximum is the calibration point.
- f. Remove voltmeter leads and replace cover. Calibration is complete.
- g. Adjust the white potentiometer on the back of the thermostat, closest to the screw terminals and furthest from the edge (there is only one white potentiometer on single setpoint stats) until the voltmeter reads the maximum airflow voltage (lowest value in volts).
- h. While watching the voltmeter, SLOWLY adjust the white potentiometer until the voltage reaches minimum flow voltage (highest value in volts). The point at which the voltage reaches minimum flow voltage when adjusting from maximum is the calibration point.
- i. If the stat has two green setpoint knobs, go to Step J. Otherwise, go to Step F.
- j. Remove the wire from terminal 3 and temporarily install a wire between terminal 3 and terminal 2 of the thermostat. This shifts control of the stat to the other green setpoint knob (Temperature Setpoint "B").
- k. Set the green Temperature Setpoint "B" to the space temperature as done in Step C for Setpoint "A", temperature (Figure 1 of the manual).
- l. If the sequence option is designed to reverse the damper motion (warmup or changeover), then repeat Step H using the other white potentiometer (NOT the one previously adjusted), and go to Step N.
- m. If the sequence option is designed to shut the damper (night setback), then perform this step. SLOWLY rotate the other white potentiometer (NOT the one previously adjusted) until the fan relay makes. Slightly "back off" potentiometer (rotate slightly in opposite direction). The fan relay should not break contact (if it does, repeat process with less "back off").
- n. Remove the temporary wire between terminal 3 and terminal 2 of the thermostat, reinstall the original wire going to terminal 3 and remove the voltmeter. Calibration is complete.

5.0 TEMPERATURE CALIBRATION, THERMOSTAT & DUCT TEMPERATURE SENSOR

5.2 Duct (Supply Air) Temperature Sensor

A 700 Series duct temperature sensor must be calibrated to the controller with which it is used. This is done at the factory for new projects, but if either the sensor or controller must be replaced in the field, field calibration is required. The supply air temperature must be between 55°F and 85°F for this procedure to be effective.

- a. Connect duct sensor to terminals 3 and 7 of controller. Connect black (-) lead of voltmeter to COM test loop on controller.
- b. If terminal 2 on controller is present, connect red (+) lead of voltmeter to it and go to Step D. Otherwise, go to Step C.
- c. If terminal 2 on the controller is not present, connect to red (+) lead of voltmeter to terminal 5 of controller. Turn thermostat temperature setpoint to full heating.
- d. Measure the supply air temperature with a calibrated temperature meter. Set the blue "Duct Sens" adjustment (R8) to that temperature.
- e. Adjust R4 (white potentiometer labeled DS Cal) until the voltage switches between -1 VDC to +15 VDC. Back off adjustment slightly (turn slightly in direction opposite original direction of rotation).
- f. Re-adjust "Dust Sens" potentiometer to halfway between expected cold and warm air temperatures (refer to Section 3.3.3).

6.0 SPARE PARTS LIST

Actuator Replacement

Current actuator uses a rotary drive, relocation of components in the control enclosure may be required when replacing units equipped with rack and pinion drive actuators.

Component	Controller Circuit Board	Actuator Replacement Part
AC Hansen "Synchron" Actuator	Black case	ACT24
	Green circuit board	ACT24
Enviro-Tec [®] ETACTRT (DC drive)	Blue circuit board	ACT24 with ETAC

If the AC actuator is functional and a new 700 Series controller is being installed, or an ACT24 is to be installed, an ETAC interface board must be ordered. This allows the DC output on the controller to drive an AC actuator.

Thermostat

SINGLE DUCT		DUAL DUCT	
Sequence	Inventory #	Sequence	Inventory #
SD701R	ETSTAT4	DD701R	ETSTAT4H
SD702R-704R	ETSTAT5	DD702R	ETSTAT8DD
SD705R	ETSTAT4W	DD701S	ETST4H
SD706R-708R	ETSTAT5W		
SD709R	ETSTAT6		
SD710R-712R	ETSTAT7		
SD713R-715R	ETSTAT5A		
SD716R-718R	ETSTAT5AW		
SD724R-726R	ETSTAT5V		
S Sequences	ETST5AW		
VARIABLE VOLUME FAN		CONSTANT VOLUME FAN	
Sequence	Inventory #	Sequence	Inventory #
FV701R-704R, FV709R-712R	ETSTAT5F	FC701R-704R, FC710R-712R	ETSTAT5
FV705R-708R, FV713R-716R	ETSTAT9F	FC705R-708R, FC717A-720R	ETSTAT9
FV717R-720R	ETSTAT5FW	FC709R	ETSTAT4
FV721R-724R	ETSTAT9F	FC713R-716R	ETSTAT5W
S Sequences	ETST5AW	S Sequences	ETST5AW

CONTROLLER

CONSTANT VOLUME FAN					
Sequence	Inventory #	Sequence	Inventory #	Sequence	Inventory #
FC701R or S	ETPR0FY	FC708R	ETPR3FS	FC717R	ETPR0FSWD
FC702R or S	ETPR1FY	FC708S	ETPR3FB	FC717S	ETPR0FBWD
FC703R or S	ETPR2FY	FC709R or S	ETPR0	FC718R	ETPR1FSWD
FC704R or S	ETPR3FY	FC710R or S	ETPR1	FC718S	ETPR1FBWD
FC705R	ETPR0FS	FC711R or S	ETPR2	FC719R	ETPR2FSWD
FC705S	ETPR0FB	FC712R or S	ETPR3	FC719S	ETPR2FBWD
FC706R	ETPR1FS	FC713R or S	ETPR0FYWD	FC720R	ETPR3FSWD
FC706S	ETPR1FB	FC714R or S	ETPR1FYWD	FC720S	ETPR3FBWD
FC707R	ETPR2FS	FC715R or S	ETPR2FYWD		
FC707S	ETPR2FB	FC716R or S	ETPR3FYWD		

6.0 SPARE PARTS LIST

CONTROLLER (continued)

SINGLE DUCT	
Sequence	Inventory #
SD701R or S	ETPR0
SD702R or S, SD724R or S	ETPR1
SD703R or S, SD725R or S	ETPR2
SD704R or S, SD726R or S	ETPR3
SD705R or S, SD709R or S	ETPR0CD
SD706R or S, SD710R or S	ETPR1CD
SD707R or S, SD711R or S	ETPR2CD
SD708R or S, SD712R or S	ETPR3CD
SD713R or S	ETPR1A
SD714R or S	ETPR2A
SD715R or S	ETPR3A
SD716R or S	ETPR1AWD
SD717R or S	ETPR2AWD
SD718R or S	ETPR3AWD
SD723R or S, SD727R or S	ETSRV
SD728R or S	ETSRV1

DUAL DUCT	
Sequence	Inventory #
DD701R	ETPROU (cold)
DD701R	ETPROHU (warm)
DD702R	ETPROU (cold)
DD702R	ETPROHU (hot)

VARIABLE VOLUME FAN	
Sequence	Inventory #
FV701R or S	ETPROFT
FV702R or S	ETPR1FT
FV703R or S	ETPR2FT
FV704R or S	ETPR3FT
FV705R / FV705S	ETPROFTS / ETPROFTB
FV706R / FV706S	ETPR1FTS / ETPR1FTB
FV707R / FV707S	ETPR2FTS / ETPR2FTB
FV708R / FV708S	ETPR3FTS / ETPR3FTB
FV709*	ETPROFTW
FV710*	ETPR1FTW
FV711*	ETPR2FTW
FV712*	ETPR3FTW
FV713*	ETPROFTWS
FV714*	ETPR1FTWS
FV715*	ETPR2FTWS
FV716*	ETPR3FTWS
FV717R or S	ETPROFTWD
FV718R or S	ETPR1FTWD
FV719R or S	ETPR2FTWD
FV720R or S	ETPR3FTWD
FV721R / FV721S	ETPROFTSWD / ETPROFTBWD
FV722R / FV722S	ETPR1FTSWD / ETPR1FTBWD
FV723R / FV723S	ETPR2FTSWD / ETPR2FTBWD
FV724R / FV724S	ETPR3FTSWD / ETPR3FTBWD

NOTE: The above also applies to ETPD / "A" sequences (e.g. SD701A) and older ETPI control sequences (e.g. SD701).

* These are obsolete PI sequences. Consult your ETI Representative for current replacement.

2.5" X 3.5" THERMOSTAT ACCESSORIES

COMPONENT	INVENTORY #
Thermostat cover and base	ETCVR
Locking thermostat cover and base	ETCVRL
Thermostat junction box adapter	JBA

2" THERMOSTAT ACCESSORIES

COMPONENT	INVENTORY #
Concealed setpoint cover, junction box adapter and mounting hardware	ETKITC
Exposed Fahrenheit setpoint knob, cover, junction box adapter and mounting hardware	ETKITPF
Exposed Celsius setpoint knob, cover, junction box adapter and mounting hardware	ETKITPC

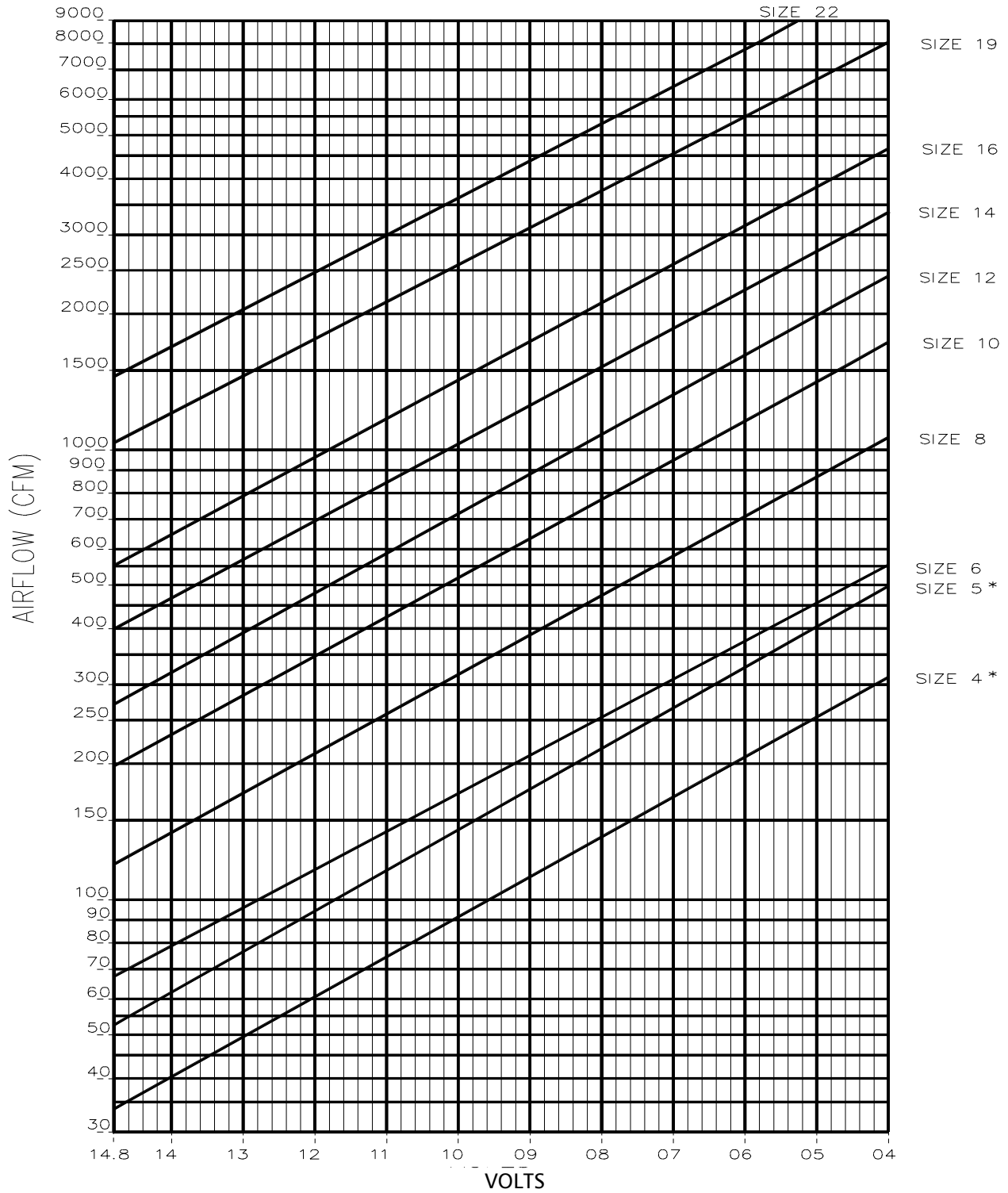

SDR, VFR, CFR • VOLTS vs. CFM

Figure 13

For air terminals with a desired minimum setpoint of 0 CFM, set minimum voltage to 17 VDC.

7.0 AIRFLOW CALIBRATION CURVES

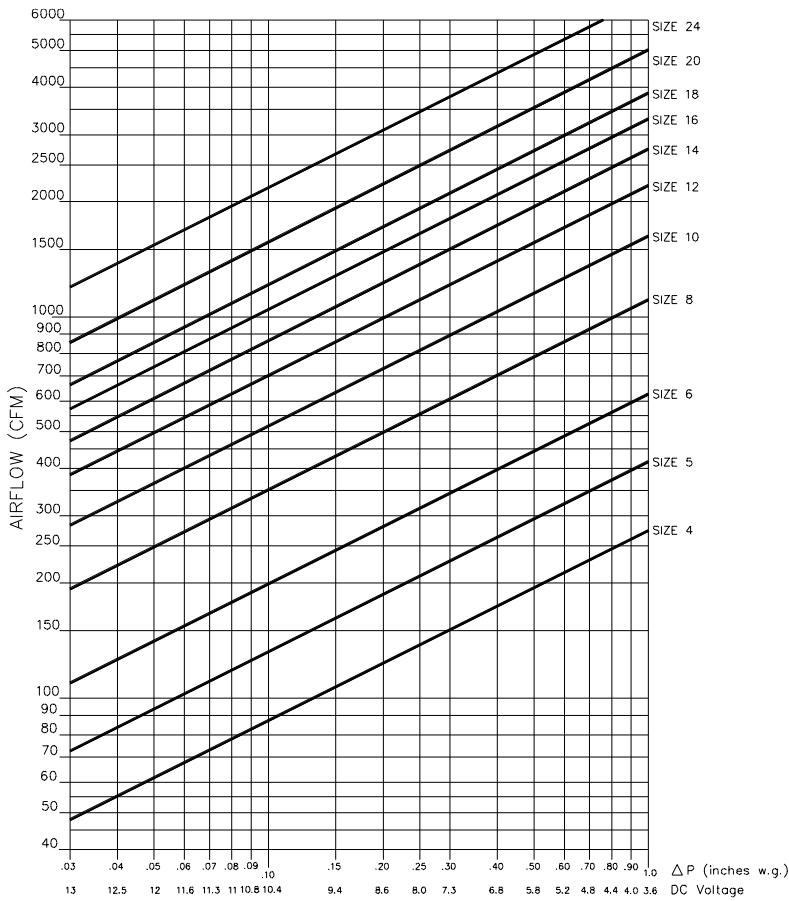
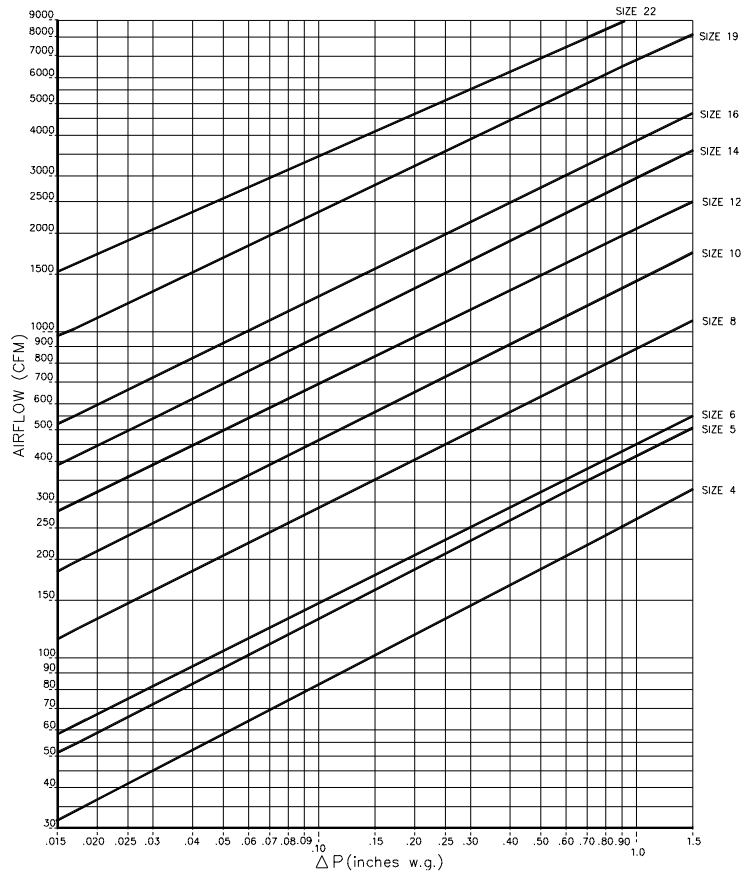

**SSD, VVF, CVF
Volts vs. CFM and
ΔP (inches W.G.)**

Figure 15

ACT24 FLOATING POINT CONTROL DIRECT COUPLED ACTUATOR



TECHNICAL DATA

On-off/floating point control
direct coupled actuator

Power Supply:

24 VAC \pm 20% 50/60 Hz
24 VDC \pm 10%

Power Consumption: 2 W

Transformer Sizing:

3 VA (Class 2 power source)

Electrical Connection:

Screw terminal (for 26 to 16 GA wire)
Recommended screw torque: 4 to 5 in-lbs.

Overload Protection:

Electronic throughout 0 to 95° rotation

Angle of Rotation:

Max 95°, adjust. with mechanical stops

Torque: Min 35 in-lb [4 Nm]

Direction of Rotation:

Reverse terminal 2 and 3 wires

Running Time:

90 - 180 sec. for 0 to 35 in-lb

Manual Override: External push button

Ambient Operating Conditions

-22°F to +122°F [-30°C to +50°C]
5 to 95% rH, non-condensing

Storage Temperature:

-40°F to +176°F [-40°C to +80°C]
5 to 95% rH, non-condensing

Housing Type: NEMA type 1

Housing Material Rating: UL94-5V

Noise Level: Less than 35 dB (A)

Servicing: Maintenance free

Weight: 1.2 lbs [0.55 kg]

APPLICATION

The device is used for floating point control of dampers in HVAC systems. The actuator mounts directly to the damper operating shaft with a universal V-bolt clamp assembly. The ACT24 replaces all former ENVIRO-TEC® actuator models, and may be used with controllers by others or ENVIRO-TEC® AC actuator drive controllers. With the addition of a model ETAC DC to AC actuator drive interface, it may also be used with ENVIRO-TEC® DC actuator drive controllers.

OPERATION

The actuator is not provided with and does not require any limit switches, but is electronically protected against overload. The angle of rotation is mechanically limited to 95°. When reaching the damper or actuator end position, the actuator automatically stops. The gears can be manually disengaged with a release button on the actuator cover. The anti-rotation strap supplied with the actuator will prevent lateral movement.

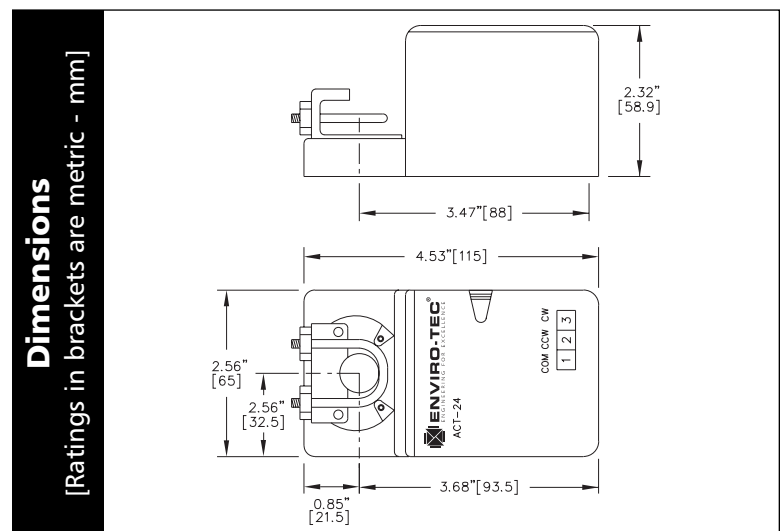

L-Type Anti-Rotation Bracket

Included with each actuator

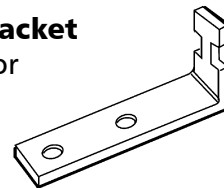

Made in Switzerland by Belimo Automation. Electronic design by ENVIRO-TEC®.

ENVIRONMENTAL TECHNOLOGIES, INC.
ENGINEERING FOR EXCELLENCE

6750 Bryan Dairy Rd. • Largo, FL 33777 • 727-541-3531 • Fax 727-545-1028
www.enviro-tec.com • Stock ID: IOM-ACT24 • 10/2000

Installation Instructions • Quick-Mount Visual Instructions

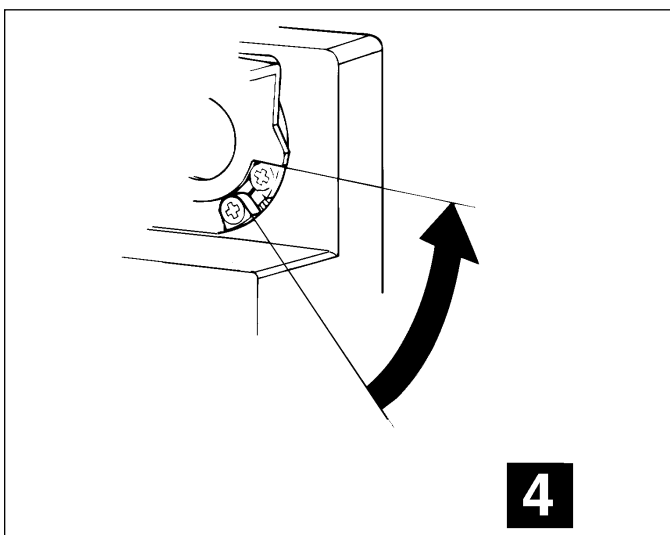
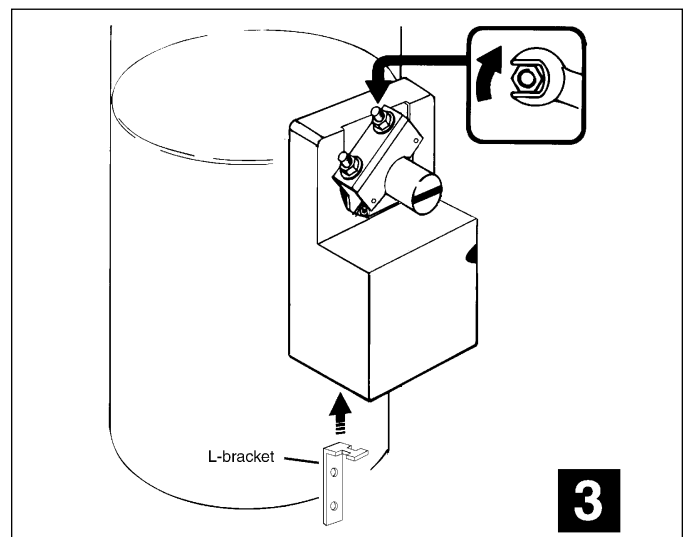
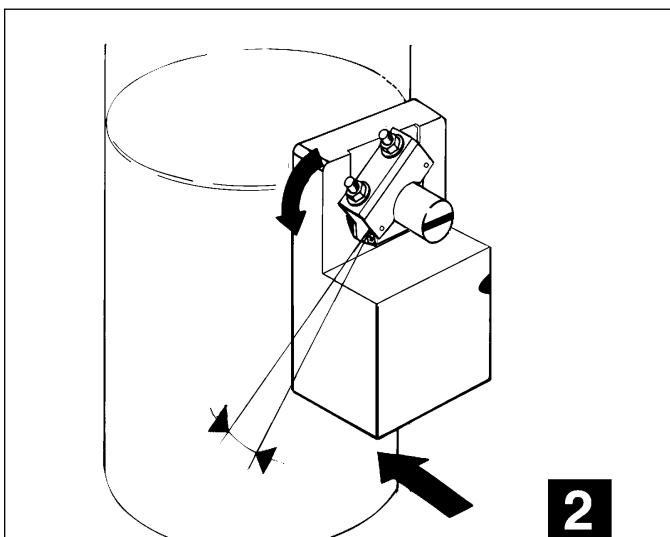
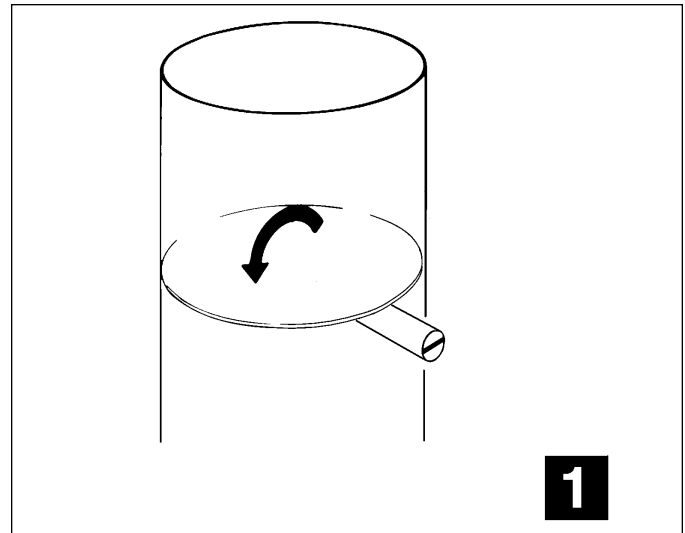
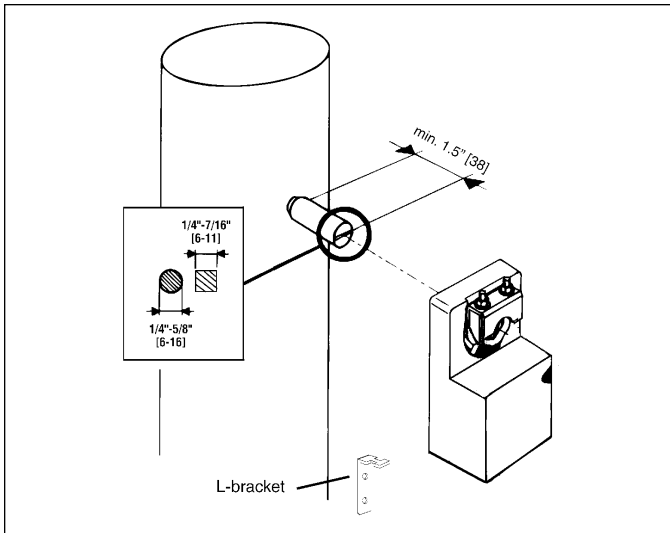

NOTES

1. Turn damper blade to its fully closed position.
2. With manual override button depressed, rotate actuator clamp to about 1/16" - 1/8" between actuator stop and clamp, depending on damper seal design. Slide actuator over shaft and finger-tighten nuts.
3. Slide anti-rotation bracket up under actuator, engaging center cut-out on actuator back. Secure bracket with self-tapping screws. Tighten the two nuts on the universal clamp with 8mm wrench, 3-5 ft-lb torque. (On dampers with edge seals, actuator will compress damper blades when reaching end position for air-tight damper).
4. Adjust end stops, if required.

Installation Instructions • Feature Operation

Manual Override

A button on the actuator cover disengages the gear train so the damper shaft can be moved manually. Release the button and the gear train is re-engaged.

Use the manual override to test the installation without power. For tight shut-off, the damper should be set at its closed position with 5° of actuator stroke remaining.

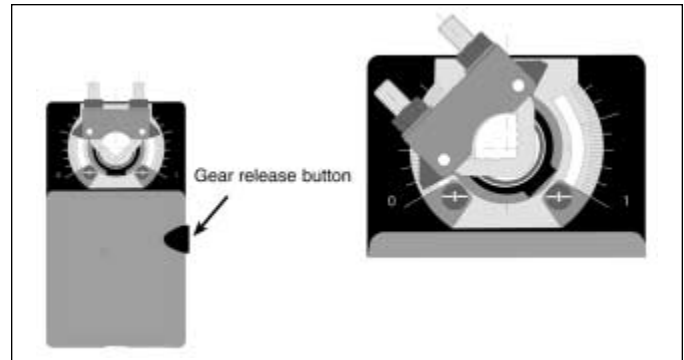

Mechanical Angle of Rotation Limiting

The adjustable stops are needed when there is no damper stop, or if you want the damper to halt rotating before it reaches its stops. The ACT24 actuator can be indefinitely stalled in any position without harm.

1. Loosen the two end stops with a No. 2 Phillips head screwdriver, being careful not to unscrew the captive nut under the slot.
2. Move the stops (in 2.5° steps) to the desired position and retighten the screws.

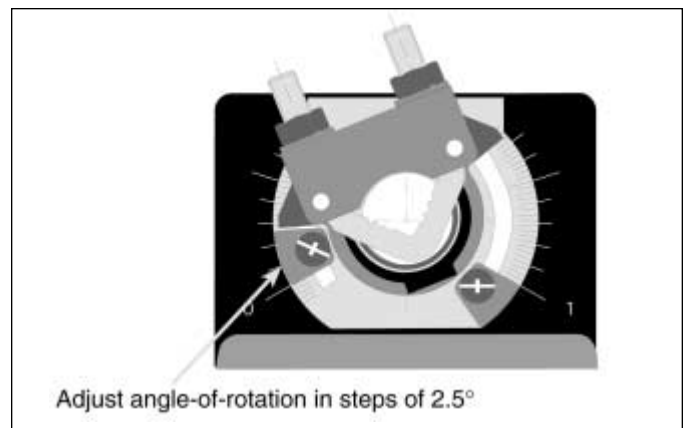

Installation Instructions • General Wiring

WARNING: The wiring technician must be trained and experienced with electronic circuits. Disconnect power supply before attempting any wiring connections or changes. Make all connections in accordance with wiring diagrams and follow all applicable local and national codes. Provide disconnect and electrical over-load protection as required.

Always read the controller manufacturer's installation literature carefully before making any connections. Follow all instructions in this literature. If you have any questions, contact the controller manufacturer and/or ENVIRO-TEC®.

Transformer(s)

The ACT24 actuator requires a 24 VAC transformer or a 24 VDC power supply, and draws a maximum of 3 VA.

(continued on next page)

Typical Wiring ENVIRO-TEC® Controls (DC Drive)

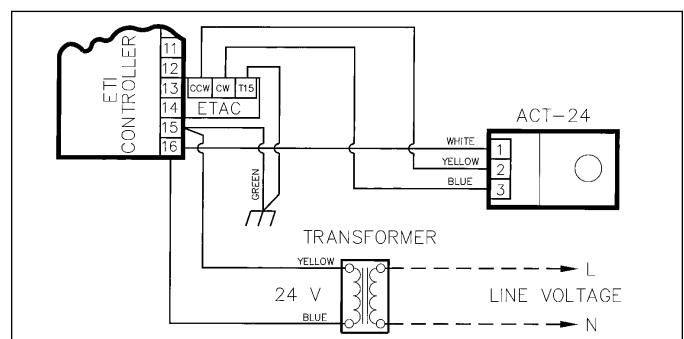

NOTES

1. An ETAC DC to AC actuator drive interface must be used with ENVIRO-TEC® 700 Series controls produced from 1990 through 2000 (blue circuit board) and all ETVT II controls except bypass pressure controller (ETDD6V).
2. Detailed installation instructions are included with ETAC interface.
3. The ACT24 in conjunction with the ETAC may be used to replace the ENVIRO-TEC® ETACTDC and ETACTRT actuators.
4. Switch actuator wires 2 and 3 to change rotation direction.

Installation Instructions • General Wiring (continued)

Typical Wiring ENVIRO-TEC® Controls (AC Drive)

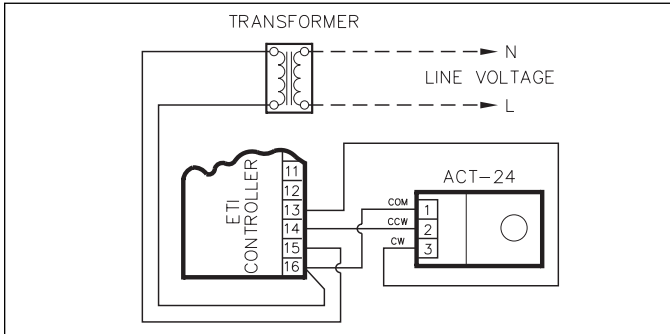

NOTES

1. Actuators may also be powered by 24 VDC.
2. Switch actuator wires 2 and 3 to change rotation direction.
3. The ACT24 may be used to replace 24 VAC, floating point control actuators by others, as well as the following ENVIRO-TEC® actuators: EDA-101, EACTUATOR, EACTD-CAD, EACTRTAD, EACTRTADS.

Typical Wiring Controls by Others

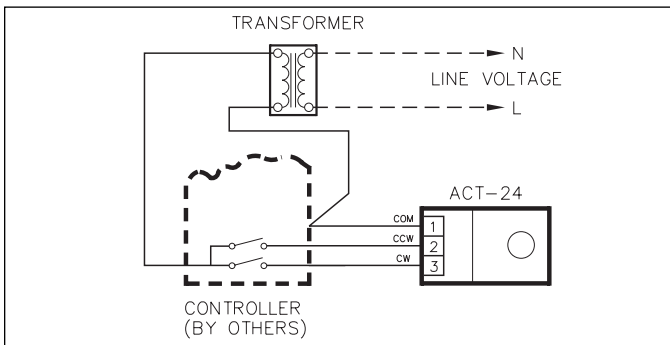

NOTES

1. Actuators may also be powered by 24 VDC.
2. Switch actuator wires 2 and 3 to change rotation direction.

CAUTION: ETI controllers may be powered from the same transformer as the actuator using the appropriate wiring diagram. It is good practice to power some other electronic or digital controllers from a separate power transformer than that used for actuators or other end devices. The power supply design in our actuators, controllers and other end devices use half wave rectification. Some controllers use full wave rectification. When these two different types of power supplies are connected to the same power transformer and the DC commons are connected together, a short circuit is created across one of the diodes in the full wave power supply, damaging the controller. Only use a single power transformer to power the controller and actuator if you know the controller power supply uses half wave rectification.

Maximum Wire Length per Actuator

Wire Size	Max. Feet	Wire Size	Max. Feet
16 Ga	1225 Ft.	20 Ga	400 Ft.
18 Ga	725 Ft.	22 Ga	200 Ft.

Twisted pair is recommended for wire runs over 20 ft.

Wire Type and Wire Installation Tips

ACT24 actuators feature an external screw terminal strip on the top of the actuator housing. Connections are numbered. The terminals are designed for 26 to 16 Ga. wire. For most installations, 18 or 16 Ga. cable works well with the ACT24 actuator. Use code approved wire nuts, terminal strips or solderless connectors where wires are joined. It is good practice to run control wires unspliced from the actuator to the controller. If splices are unavoidable, make sure the splice can be reached for possible maintenance. Tape and/or wire tie the splice to reduce the possibility of the splice being inadvertently pulled apart. Wires should not be run parallel to, or in the same bundle or conduit with, high voltage wiring.

Overload Protection

All ACT24 actuators are electronically protected against mechanical overload. In the ACT24, an electronic circuit maintains the current at a level which will not damage the motor, while providing adequate holding torque.

Checkout Instructions

1. Disconnect actuator from controller.
2. Apply 24 VAC to COM and CW leads of actuator. Actuator should rotate in a clockwise direction.
3. Apply 24 VAC to COM and CCW leads of actuator. Actuator should rotate in a CCW direction.
4. If actuator moves in both directions, it is operational.
5. If actuator does not rotate, it may be at its stop, at the terminal unit's stop, or there is a problem with the terminal unit's damper. Loosen universal clamp screws to free actuator from damper shaft, check to make sure it is not against its own stop, and repeat steps 2 and 3 above.
6. If actuator does not move in either direction, replace.

ACT24 Typical Specification

Control damper actuators shall be electronic direct coupled type which require no crank arm and linkage. Actuators shall be warranted 18 months from shipment or 12 months from start-up, whichever comes first. Actuators will be manufactured under ISO 9001 International Quality Control Standards. Actuators shall have manual override on the cover, and be protected from overload at all angles of rotation. Actuator will be provided with screw terminal strip for electrical connections and shall be as manufactured by Belimo, using circuitry designed by ENVIRO-TEC®.