



ELECTRIC HEATERS

OPERATION AND MAINTENANCE MANUAL

Stock ID: IOM-EH

March, 2007

©2007 Environmental Technologies

Part No. PX-00-0164

TABLE OF CONTENTS

DESCRIPTION	PAGE
Important Safety Precautions	3
Replacement Parts	3
Pre Start-Up	4
Receiving and Inspection	4
Unit Placement	4
Clearance	4
Electric Heater Warning Labels	5
Minimum Wire Gauge	5
Field Wiring	6
Preventative Maintenance	6
Ampere Reading per kW.....	6
Figure 1: Airflow Switch Probe	6
Troubleshooting Guide	7
Troubleshooting Guide, Proportional Heat Control (SSR).....	8
Sample Submittal Wiring Diagrams	11 - 12

SAFETY CONSIDERATIONS

The equipment covered by this manual is designed for safe and reliable operation when installed and operated within its design specification limits. To avoid personal injury or damage to equipment or property while installing or operating this equipment, it is essential that qualified, experienced personnel perform these functions using good judgement and safe practices. See the following cautionary statements.

DANGER

ELECTRICAL SHOCK HAZARDS. All power must be disconnected prior to installation and servicing this equipment. More than one source of power may be present. Disconnect all power sources to avoid electrocution or shock injuries.

HOT PARTS HAZARD. Electric Resistance heating elements must be disconnected prior to servicing. Electric Heaters may start automatically, disconnect all power and control circuits prior to servicing to avoid burns.

WARNING

Check that the unit assembly and component weights can be safely supported by rigging and lifting equipment.

All assemblies must be adequately secured during lifting and rigging by temporary supports and restraints until equipment is permanently fastened and set in its final location.

All unit temporary and permanent supports must be capable of safely supporting the equipment's weight and any additional live or dead loads that may be encountered. All supports must be designed to meet applicable local codes and ordinances.

All fastening devices must be designed to mechanically lock the assembly in place without the capability of loosening or breaking away due to system operation and vibration.

REPLACEMENT PARTS

- Replacement parts should be ordered from the local ENVIRO-TEC® representative. Factory replacement parts must be used to maintain agency listings. Any substitutions and/or modifications not authorized by the factory will void the unit warranty, the agency listing, and could result in personal injury and/or property damage.

When ordering parts, the following information must be supplied to ensure proper part identification:

- 1) Complete unit catalog number on unit label
- 2) Complete parts description, including any identification numbers

To find your nearest ENVIRO-TEC® representative, visit our web site at www.enviro-tec.com or contact the factory at 727-541-3531.

PRE START-UP

WARNING: Improper installation, adjustments, alterations, service or maintenance can cause injury and property damage, as well as possible voiding of factory warranty. For assistance or additional information, consult a qualified contractor and your local ENVIRO-TEC® representative.

RECEIVING AND INSPECTING

- Thoroughly examine the exterior and interior of all units for transportation damage. If damage is found, immediately file a claim with the carrier. Note the damage on the bill of lading when signing for the shipment.
- Check the bill of lading to verify that all items shown (including loose items) have been received. Notify the ENVIRO-TEC® representative of any shortages or items shipped in error.
- Do not handle the unit's heating elements, as permanent damage may occur.

UNIT PLACEMENT

CAUTION: Never energize a heater without proper airflow.

- Install ductwork to comply with ASHRAE Fundamentals Handbook, SMACNA, NFPA 90A and local code.
- ENVIRO-TEC® supplied heaters must be installed in compliance with all National and Local Codes. Improper installation of these units can result in the removal of the Listing Label and/or voiding of the Warranty. Airflow and airflow patterns are important to the operation and life of the heater (see airflow graphs on page 5). Proper airflow will also prevent nuisance tripping of the thermal safety devices.

CLEARANCE

- All electric heat units are ETL listed for zero clearance to combustibles.
- All electrical panels must have adequate working space in front of, above and to the side of heater to meet NATIONAL ELECTRICAL CODE criteria Section 110.26, or other pertinent local codes.

ELECTRIC HEAT WARNING LABELS

The labels shown below are located on the door of all electric heat units in compliance with our ETL listings to UL 1995 and CAN/CSA C22.2 No. 236. Adherence to these warning labels prevents possible injury or damage to equipment and/or property.

Disconnect Hazard Labels

Ensure that all power has been disconnected prior to servicing equipment.



ENVIRO-TEC Heater Labels

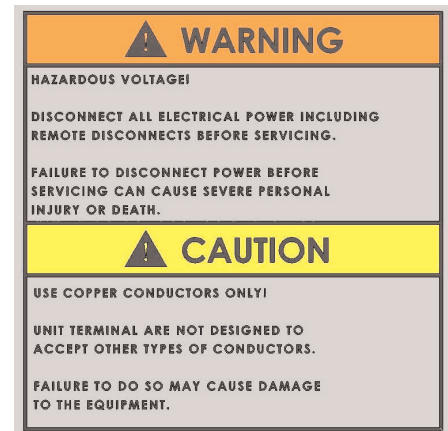
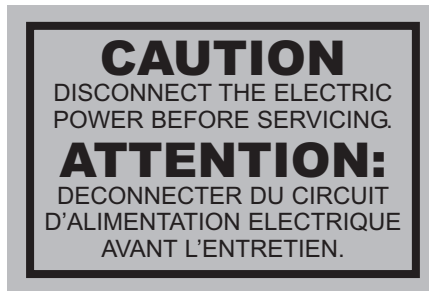

Tutco Heater Label

Start-Up Caution Label

Tighten all wiring lugs and terminals prior to connecting power to the unit, as they may loosen during transportation.

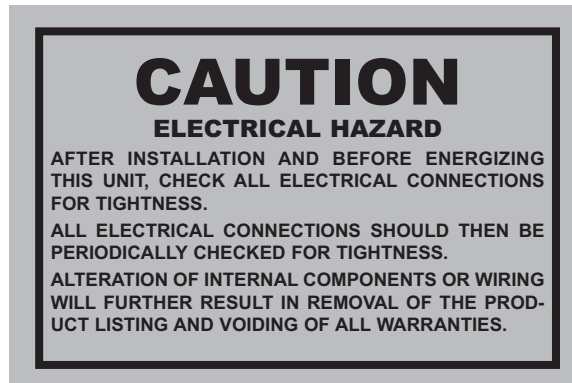

MINIMUM COPPER WIRE GAUGE (from Table 310-16 NEC 2002 wire rated 75°C)

AMPERES	MINIMUM WIRE GAUGE	AMPERES	MINIMUM WIRE GAUGE
15	14 AWG	175	2/0 AWG
20	12 AWG	200	3/0 AWG
30	10 AWG	230	4/0 AWG
50	8 AWG	255	250 kcmil
65	6 AWG	285	300 kcmil
85	4 AWG	310	350 kcmil
100	3 AWG	335	400 kcmil
115	2 AWG	380	500 kcmil
130	1 AWG	420	600 kcmil
150	1/0 AWG		

POWER WIRING		CONTROL WIRING Stages		TRANSFORMER WIRING Primary Voltage (same as Power Wiring) SECONDARY 24 Volt	
L1	Black	Step 1	Red	Negative	Yellow
L2	Red	Step 2	Purple	Positive	Blue
L3	Blue	Step 3	Orange		
N	White	Step 4	Brown		
Ground	Green	Fan Output	Black		

NOTE: Units with wire gauges 8 AWG and greater will be color coded with electrical tape.

FIELD WIRING

NOTE: Prior to installing any wiring, check the unit name plate for main power voltage, control voltage and maximum overcurrent protection. Operating a heater at other than the specified voltage and phase can result in fire or electrical hazard. All field wiring must comply with NATIONAL ELECTRIC CODE and local code requirements. A point-to-point wiring diagram is located on the inside of the electric heat control panel door.

- Use copper conductors only with a minimum of 75°C insulation.
- Tighten all wiring lugs and terminals prior to connecting power to the unit, as they may loosen during transportation.
- Connect the power lines to the power distribution terminals inside the control enclosure and tighten to 35 inch-pounds (.4kg meters). If a factory wired disconnect switch is installed, connect the power lines to the line side of the switch. The line block or disconnect is rated at 125% of nominal heater amperes based on 75°C wire.
- When mounting field installed components, do not jumper out or rewire any factory wiring without written approval from Environmental Technologies, Inc. only. Violation will void warranty and listing.
- Energize unit and check all controls for proper operation. Do not operate unit without proper airflow.

ELECTRIC HEATER PREVENTATIVE MAINTENANCE CHECKS & SERVICE SCHEDULE

CAUTION!

DISCONNECT ALL POWER SOURCES BEFORE ATTEMPTING TO SERVICE OR CLEAN HEATER

Before, and at Midpoint of the Heating Season:

- Check all electrical connections for tightness and broken terminations.
- Check all wiring for deterioration or over heating.
- Check unit for dirt or dust, and wipe clean (except elements).
- Check the element section for obstructions and debris.
- Check all components for wear and physical damage.
- Check all safety devices for proper operation.
- Check temperature controls for proper operation.

CAUTION:

In the event of thermal protection failure, it is recommended that a qualified service person investigate the cause of failure prior to returning the heater to normal service.

AMPERE READING PER KW	
VOLTAGE/PHASE	AMPERES/KW
115/1	8.70
120/1	8.33
208/1	4.80
230/1	4.35
240/1	4.16
277/1	3.61
480/1	2.08
208/3	2.77
230/3	2.51
240/3	2.40
460/3	1.26
480/3	1.20
575/3	1.00

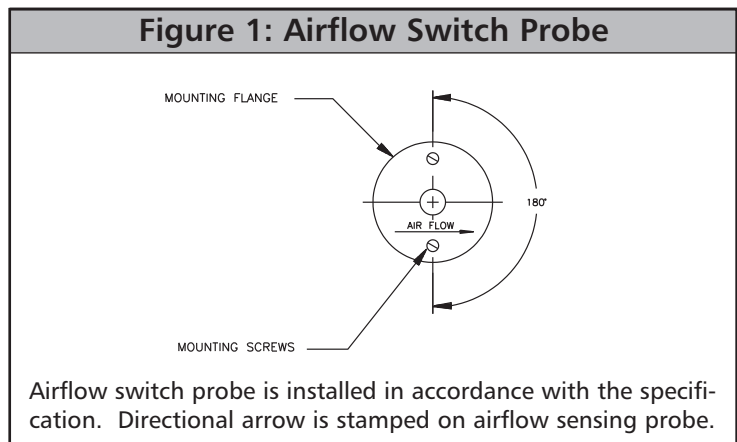

TROUBLESHOOTING GUIDE (ENVIRO-TEC and Tutco)

- Check installation instructions and wiring diagrams to ensure heater is wired and installed properly.

COMMON SYMPTOMS	POSSIBLE CAUSE	REMEDY
Heater Does Not Operate	No Power	<ul style="list-style-type: none"> • Check disconnect
	No Control Voltage	<ul style="list-style-type: none"> • Check control signal (i.e. 24volt) • Check transformer and transformer fusing (if applicable), replace if necessary
	Blown Fuse	<ul style="list-style-type: none"> • Replace fuse
	Open Limit (primary or secondary)	<ul style="list-style-type: none"> • Replace limits or reset as applicable • Check for continuity across limit to determine if open, replace as necessary
	Airflow Incorrect Direction	<ul style="list-style-type: none"> • Check sensing tube, rotate if needed (see Figure 1)
	Low Airflow Static Pressure	<ul style="list-style-type: none"> • Increase airflow
	Damaged Elements	<ul style="list-style-type: none"> • Check for open or damaged elements and replace as necessary
Low or High Temperature Rise	Incompatible Thermostat or Controller	<ul style="list-style-type: none"> • Check wiring • Check for compatibility
	Problems with Additional Stages	<ul style="list-style-type: none"> • Check location of thermostat; may be installed in a "too hot" or "too cold" location. Check heat outputs on controller. • Check contactors for open coil • Check for damaged elements
	Incorrect CFM	<ul style="list-style-type: none"> • Check for blocked duct or location of heater
Short Cycling	Improper Airflow	<ul style="list-style-type: none"> • Check for even airflow across the face of element section • Check for blocked duct • Verify ESP of .075 • Verify installation per SMACNA and ASHRAE guidelines • Check for dirty filters
	Low CFM	<ul style="list-style-type: none"> • See remedies for "Improper Airflow" • Check air velocity of 70 CFM per kW
Heater w/SSR Does Not Operate	Incorrect Signal Applied	<ul style="list-style-type: none"> • Verify signal input • See pages 8 - 10
	Interface Board Fuse Blown	<ul style="list-style-type: none"> • Replace fuse

PROPORTIONAL HEAT CONTROL (SSR) TROUBLESHOOTING GUIDE

| ENVIRO-TEC HEATERS |

CAUTION: Lethal voltages are present in the heater control enclosure. Use extreme caution when taking measurements in these units. Always disconnect power before removing or re-applying any connections.

1. Before applying power, verify wiring matches diagram in cover of heater control enclosure, and that correct line voltage has been wired to heater line block.
2. Verify 24 VAC +15% or -10% between P1 and P2 of interface circuit board (ETPHCI, ETPHCV2, etc., depending on input).
3. The table below lists responses to input signal by interface model as explained in step 4. If any of these inputs cannot be obtained, refer to the literature on the device that is supposed to provide the input. Otherwise, proceed to step 4.

INTERFACE MODEL	"PULSE" INPUT	FULL OFF INPUT	FULL ON INPUT	INPUTS
ETPHCI	12.0 mA	4.0 mA	20.0 mA	Sig, Com
ETPHCV2	6.0 VDC	2.0 VDC	10.0 VDC	Sig, Com
ETPHCC	50%	0 VAC	24 VAC	Sig, Com
ETPHCC1	50%	0 VAC	24 VAC	+18, Com

4. Apply Full Off Input per table above. If the unit is three phase, verify that the LED on the SSR (solid state relay) is off. If the unit is single phase, measure voltage between P4 and P6 and verify 0.3 VDC + or - 0.3 VDC. Replace the interface circuit board if the voltage is higher than specified, or the LED is on.
5. Apply Full On Input per table above. If the unit is three phase, verify that the LED on the SSR (solid state relay) is on. If the unit is single phase, measure voltage between P4 and P6 and verify between 3 and 5 VDC.
6. If the module provided is an ETPHCC or ETPHCC1, go to step 7. Apply "Pulse" Input per table above. If the unit is three phase, verify that the LED on the SSR (solid state relay) is flashing at an interval of about one second. If the unit is single phase, the voltage between P4 and P6 of the interface board should vary between the Full Off and Full On voltages in steps 4 and 5 in intervals of about one second. NOTE: Some voltmeters will not respond this quickly, so the value of the voltages may not appear to be correct; however, if the voltage appears to be changing at regular intervals, it may be assumed that this function is operating properly. This completes the low voltage portion of the unit test. Go to step 8.
7. For the ETPHCC or ETPHCC1, the associated consignment controller must be directed to output a 50% On pulse width modulation signal. For three phase, verify that the LED is pulsing at regular intervals. The rate of the pulse is based on the output from the consignment controller. If the unit is single phase, the DC voltage between P4 and P6 of the interface board should vary between the full Off and full On voltages in steps 4 and 5. NOTE: Some voltmeters will not respond this quickly, so the value of the voltages may not appear to be correct; however, if the voltage appears to be changing at regular intervals, it may be assumed that this function is operating properly.
8. If the heater always remains energized when power is applied, remove the wire from P4 of the interface circuit board. If the heat remains on, there is a wiring error or the SSR is defective. CAUTION: Remove Power From the Unit Before Proceeding With the Next Step.
9. If the heater is always de-energized when power is applied, remove the line and load connections to the proportional heat control and temporarily tie them together. If the system is a three phase arrangement, do the phases one at a time. (NOTE: Always remove power from the unit before moving to the next phase). Make sure there is no danger of the temporary connection shorting to another component or the chassis. Briefly reapply power. If the section of heat under test now energizes, the SSR is defective. If heater still will not energize, one of the heater safety devices (limits, safety contactor or airflow switch) or elements is defective.

PROPORTIONAL HEAT CONTROL (SSR) TROUBLESHOOTING GUIDE | TUTCO HEATERS, ALL POWER MODULES |

- Install the ammeter on the line voltage input wire of heater.
- This is your primary source of information to know if the heater is operative or not.
- A multimeter set in Ohms cannot be used to confirm that the high voltage contact of a power module is closed.
- You cannot confirm R820 power module operation unless a load is applied

NO DEMAND, ex. 277 Vac

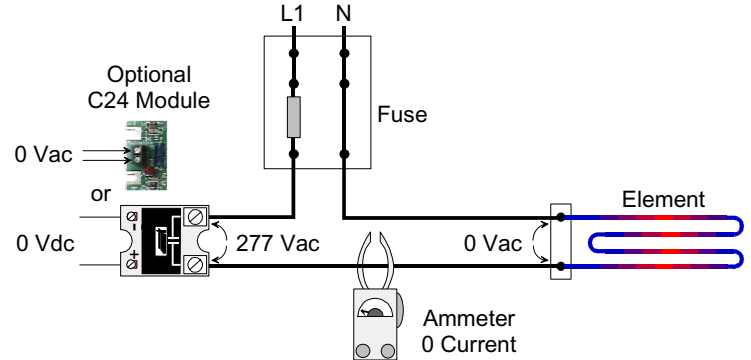

WITH 100 % HEATING DEMAND, ex. 277 Vac

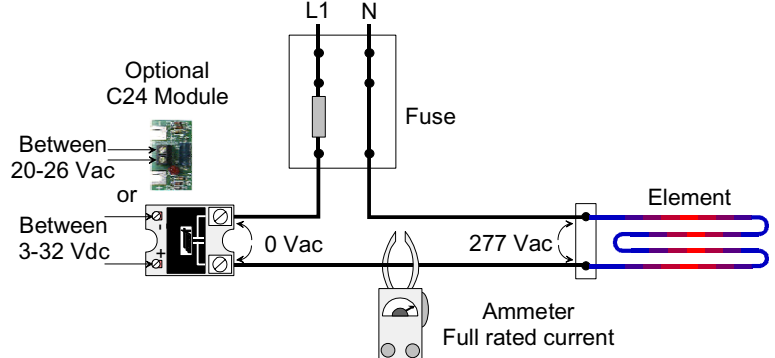

INTERFACE MODULE CONTROL SIGNAL WIRING CONNECTION DIAGRAM

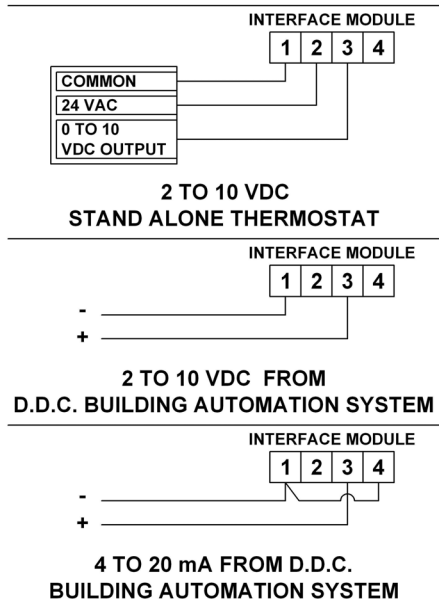

| TUTCO HEATER INTERFACE |

**PROPORTIONAL HEAT CONTROL (SSR) TROUBLESHOOTING GUIDE
| TUTCO HEATERS, R820 SCR'S |**

NO DEMAND, ex. 480 Vac

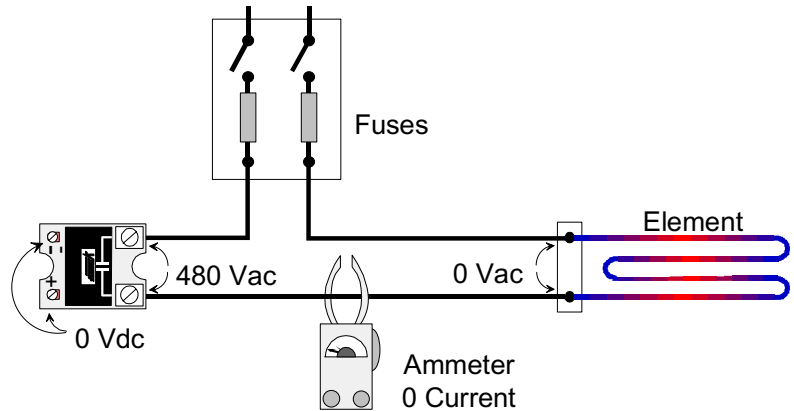
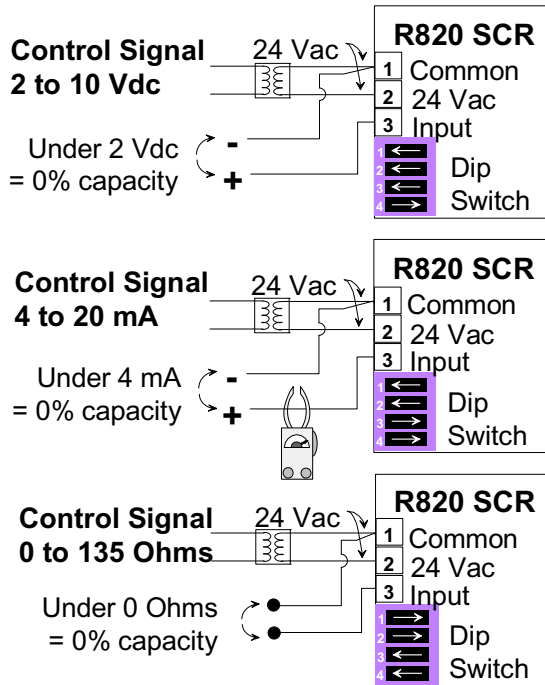

WITH 100 % HEATING DEMAND, ex. 480 Vac

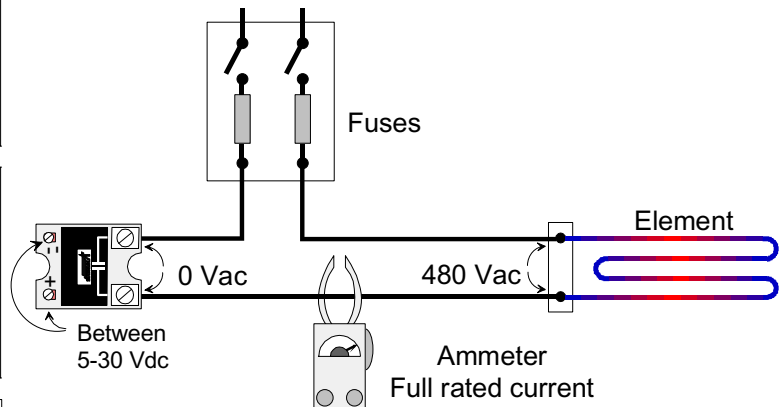
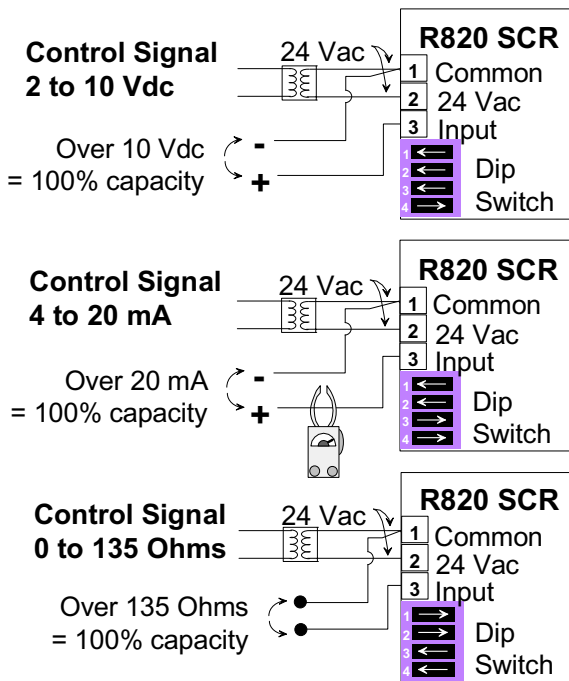

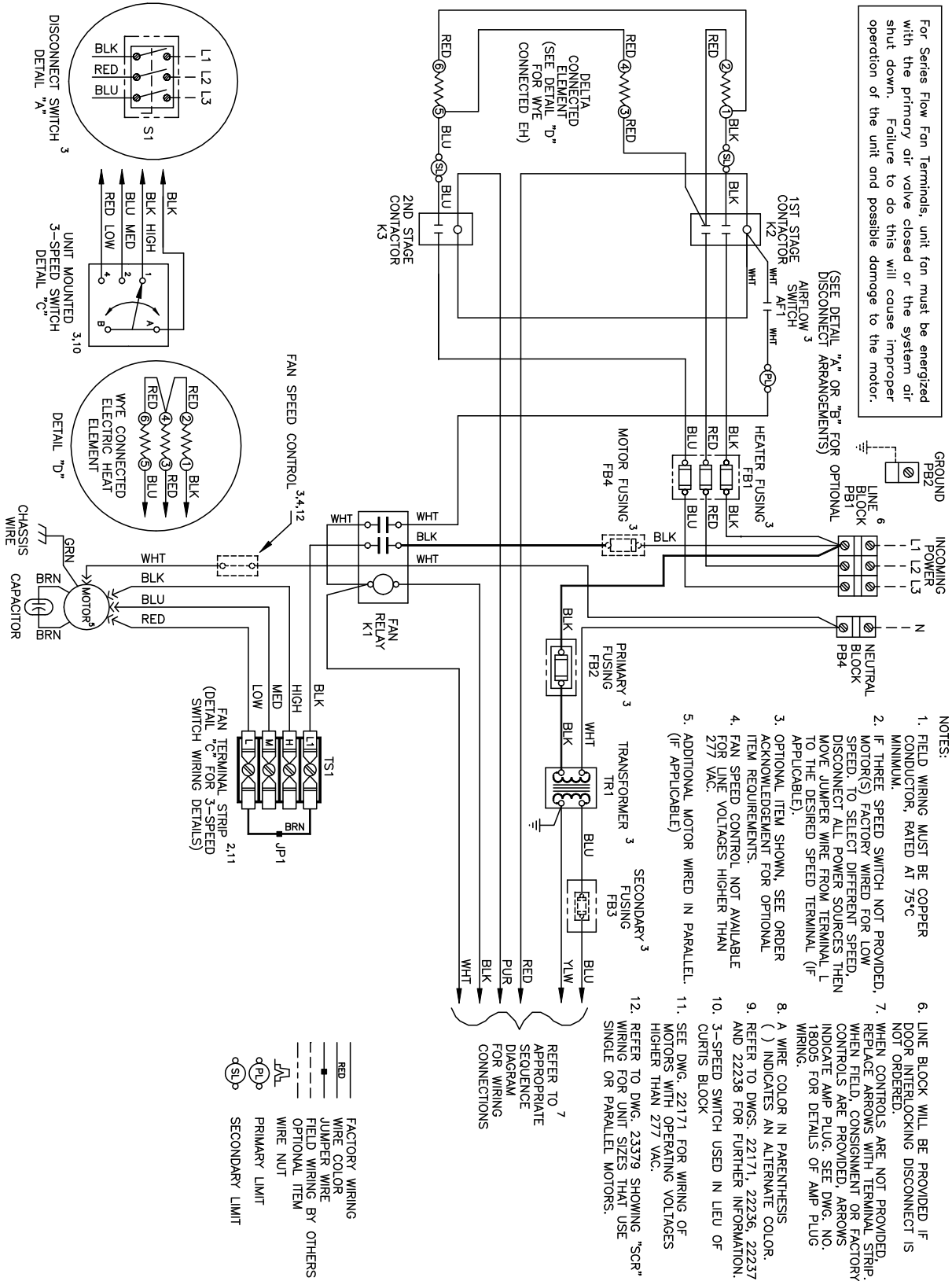

ENVIRO-TEC HEATERS, Typical Wiring Diagram
 Not to be used for submittal or actual field wiring purposes.

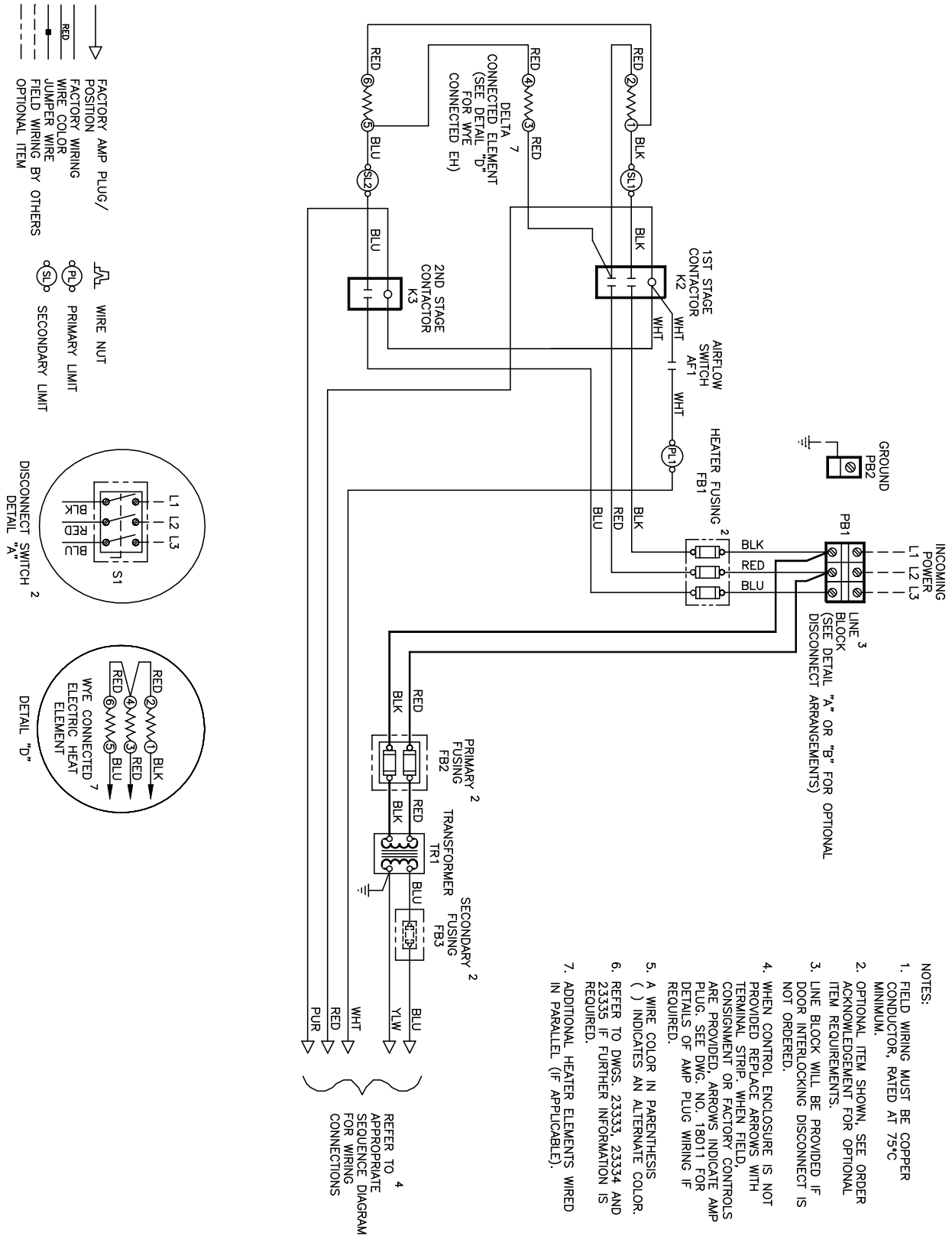

ENVIRO-TEC HEATERS, Typical Wiring Diagram
Not to be used for submittal or actual field wiring purposes.